

LECTURE 3

Rune Mittet
Chief Scientist, EMGS
Adjunct Professor, NTNU

Spot the difference.

Reflection and refraction

A CSEM - seismic comparison

Reflection and refraction



What happens if the listener is separated from the shouter?

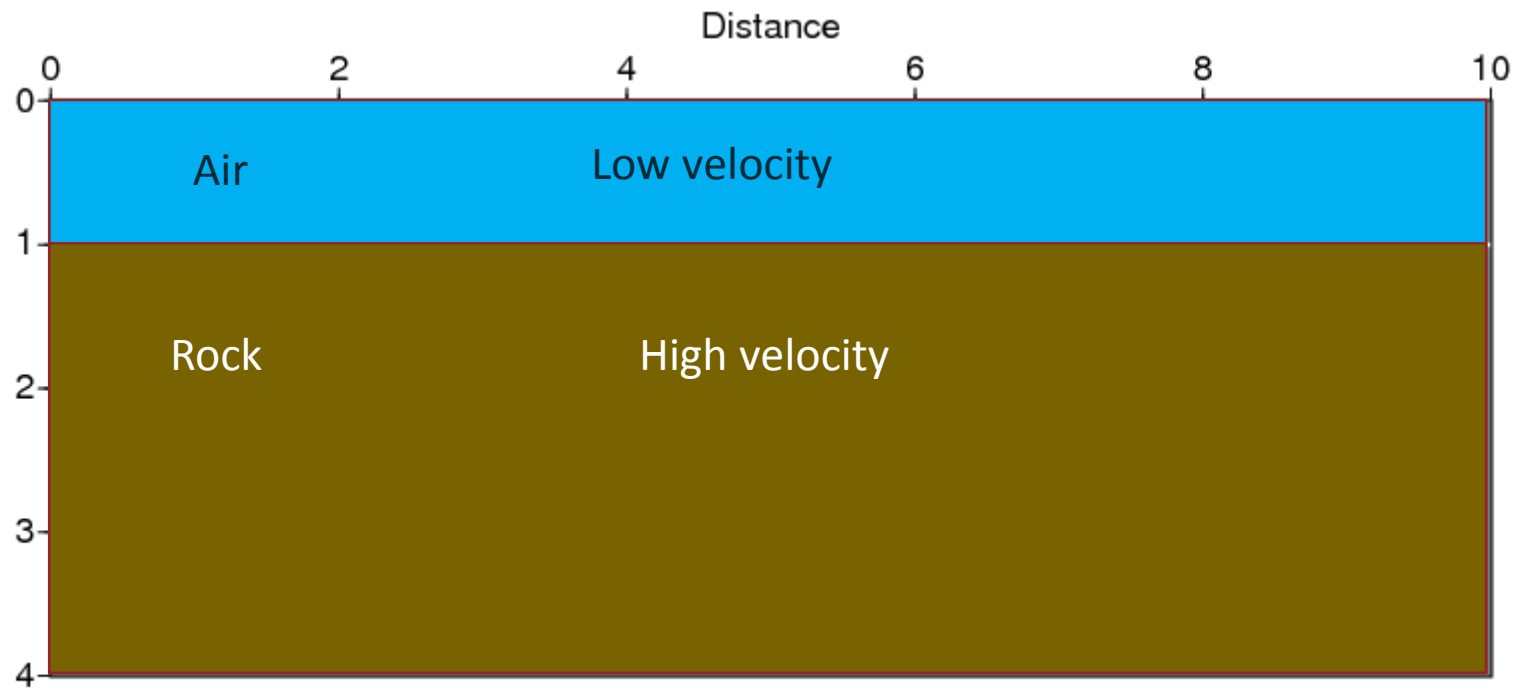

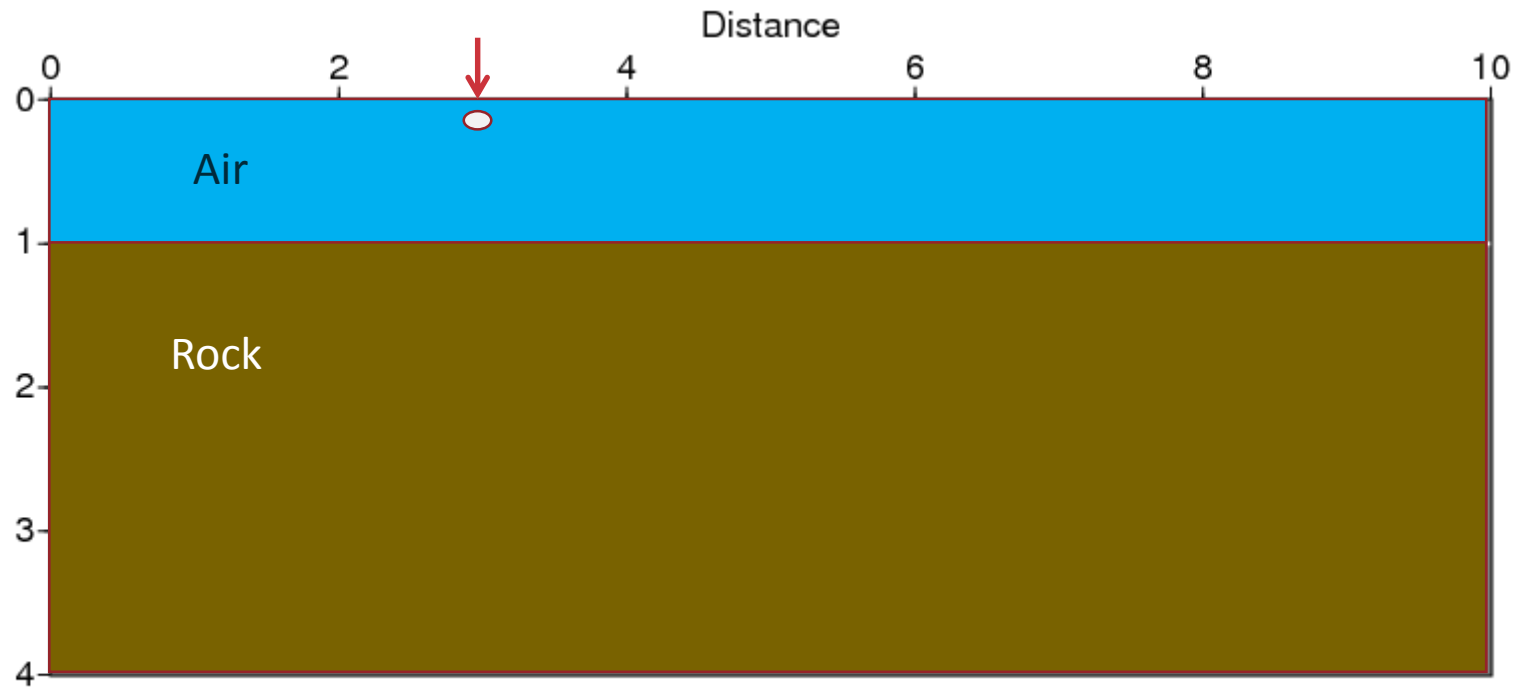

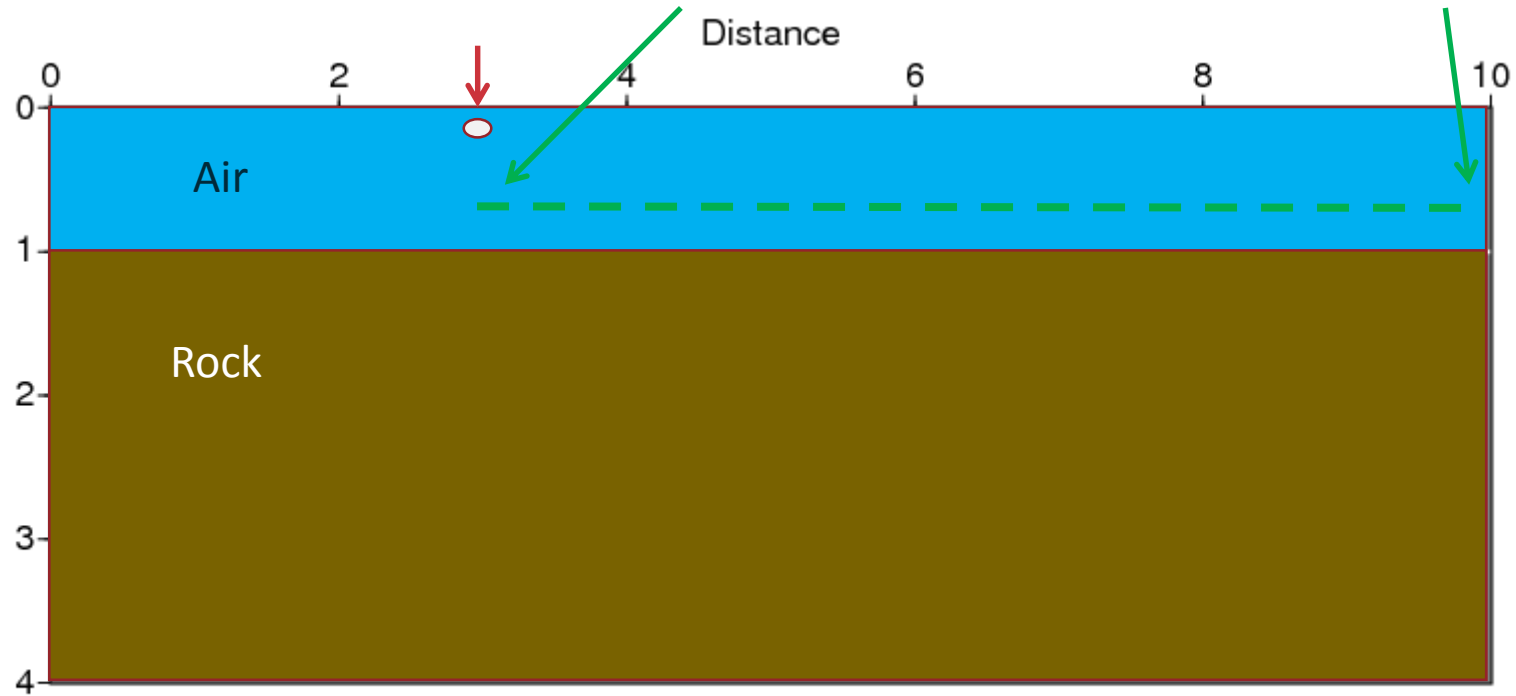

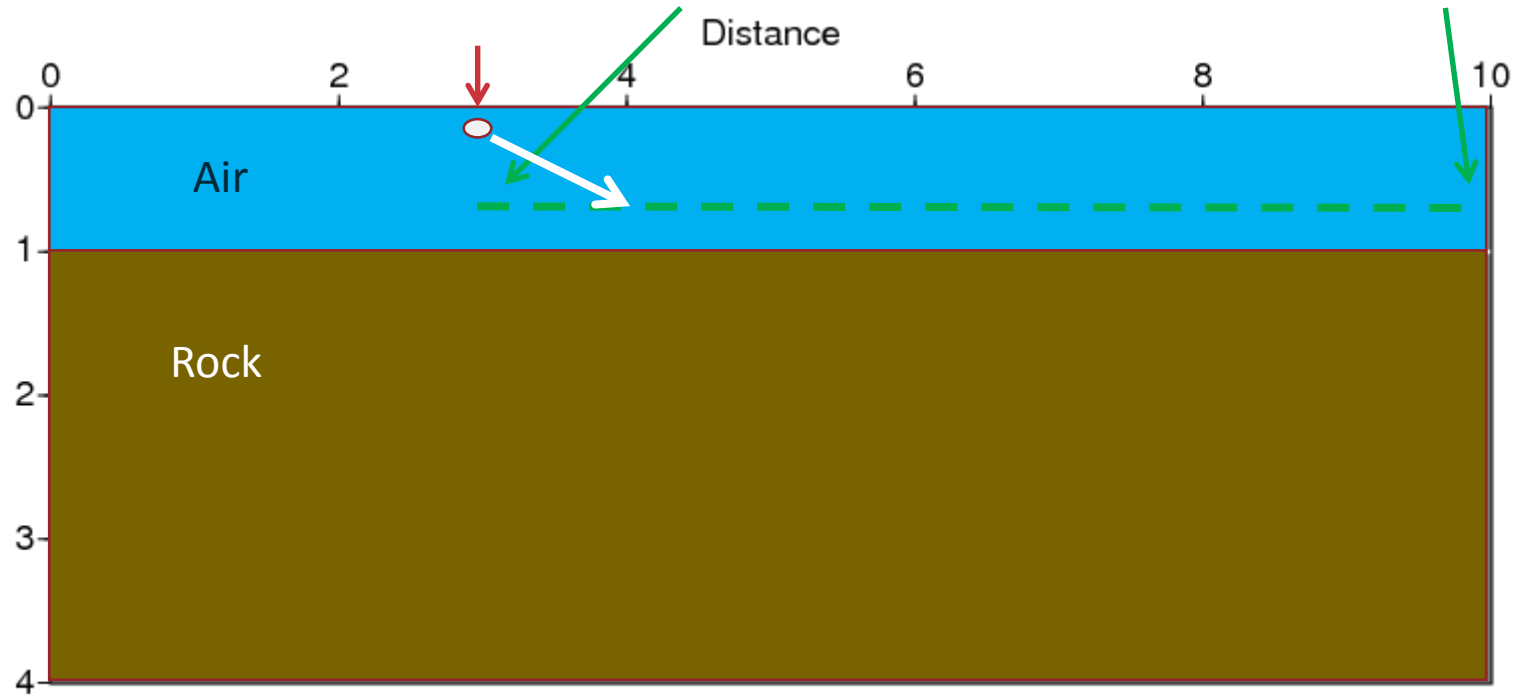

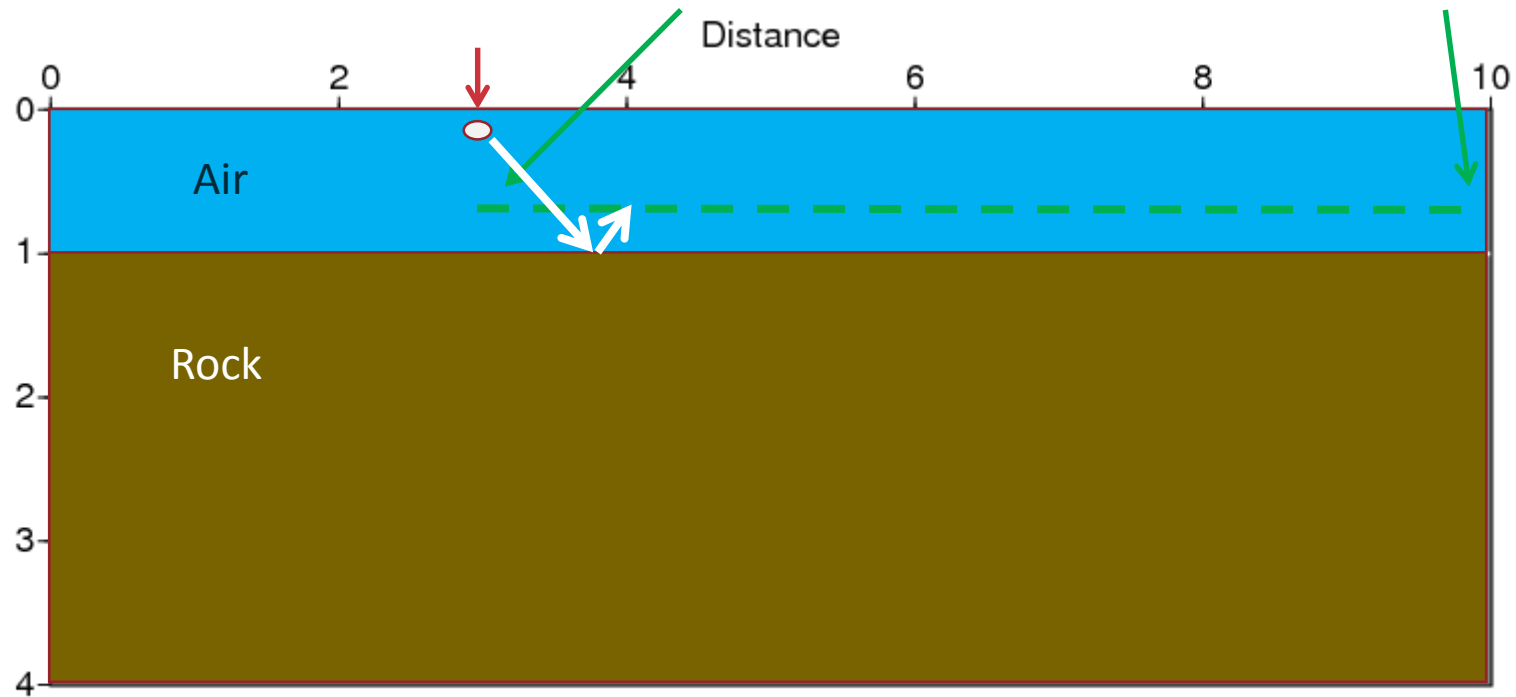

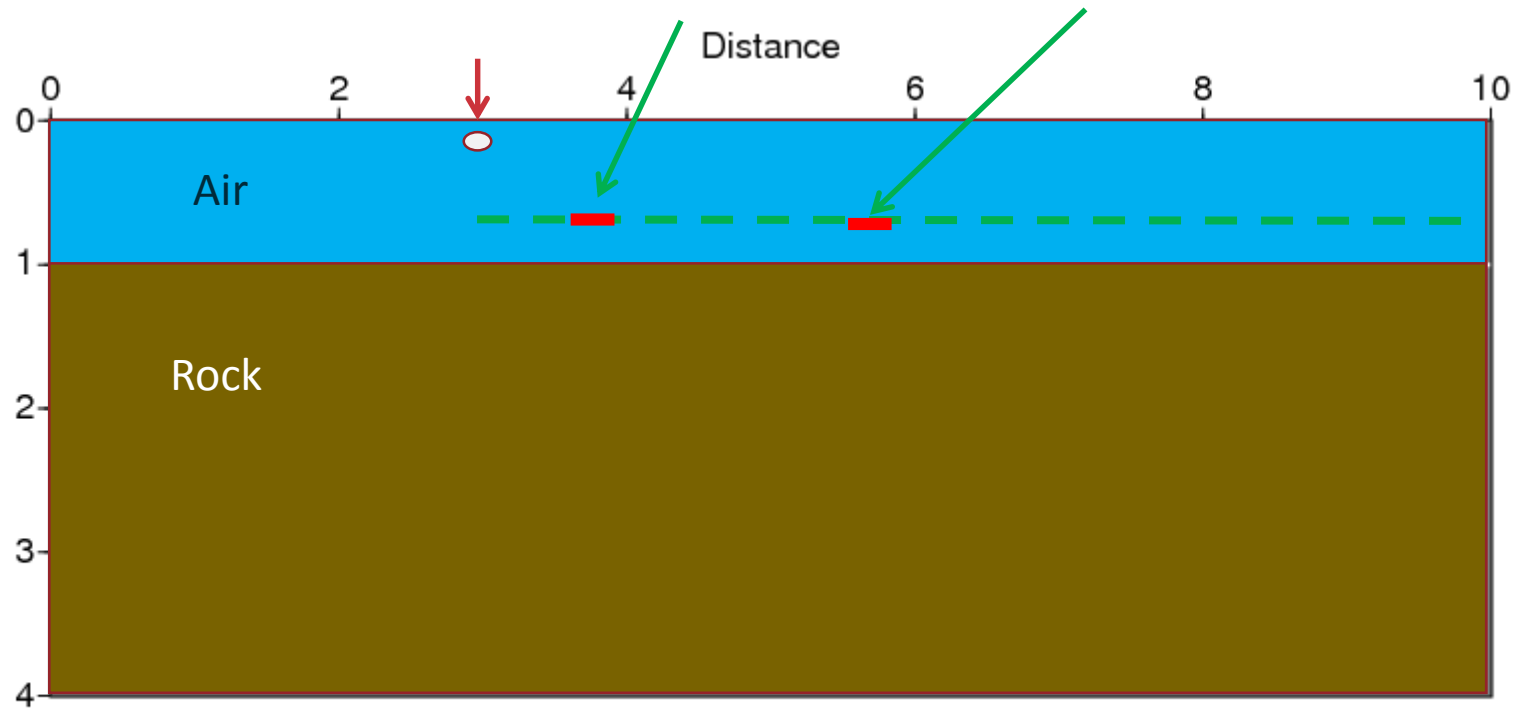

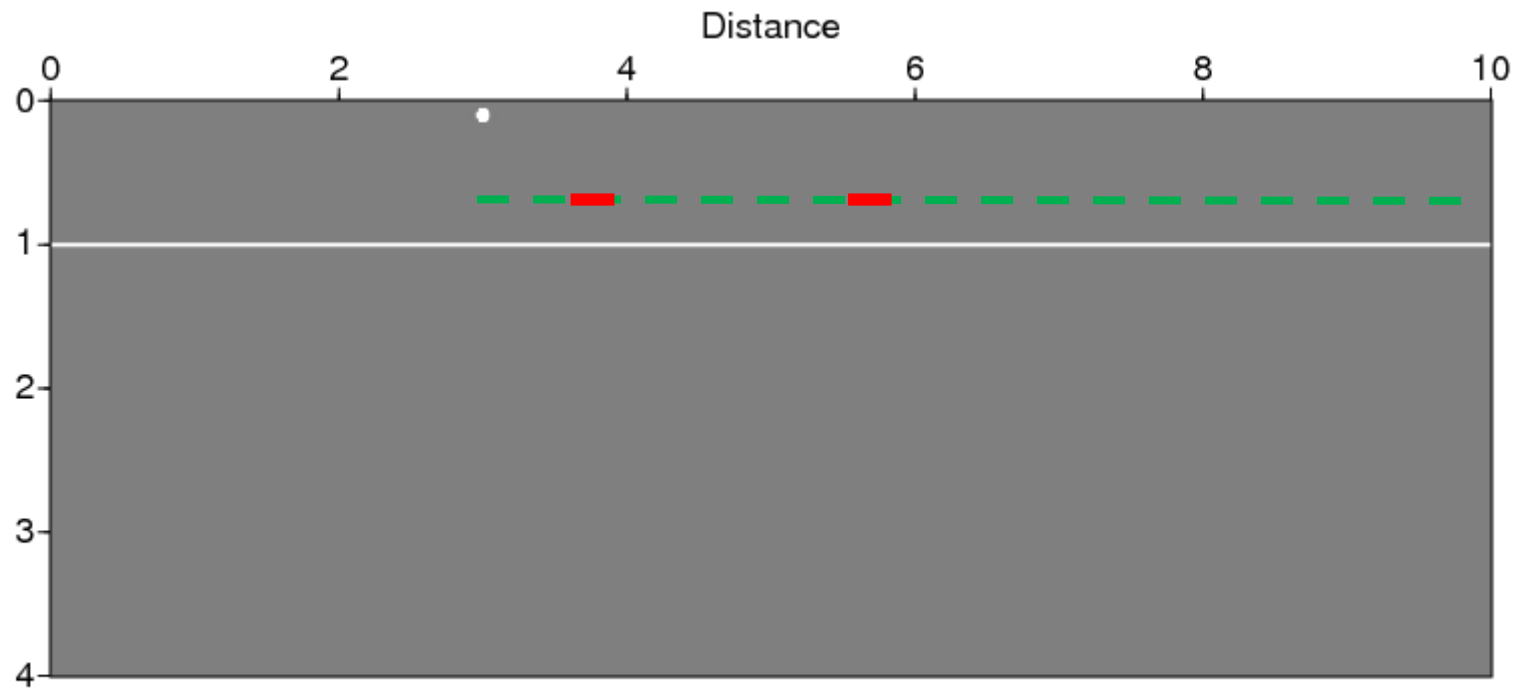

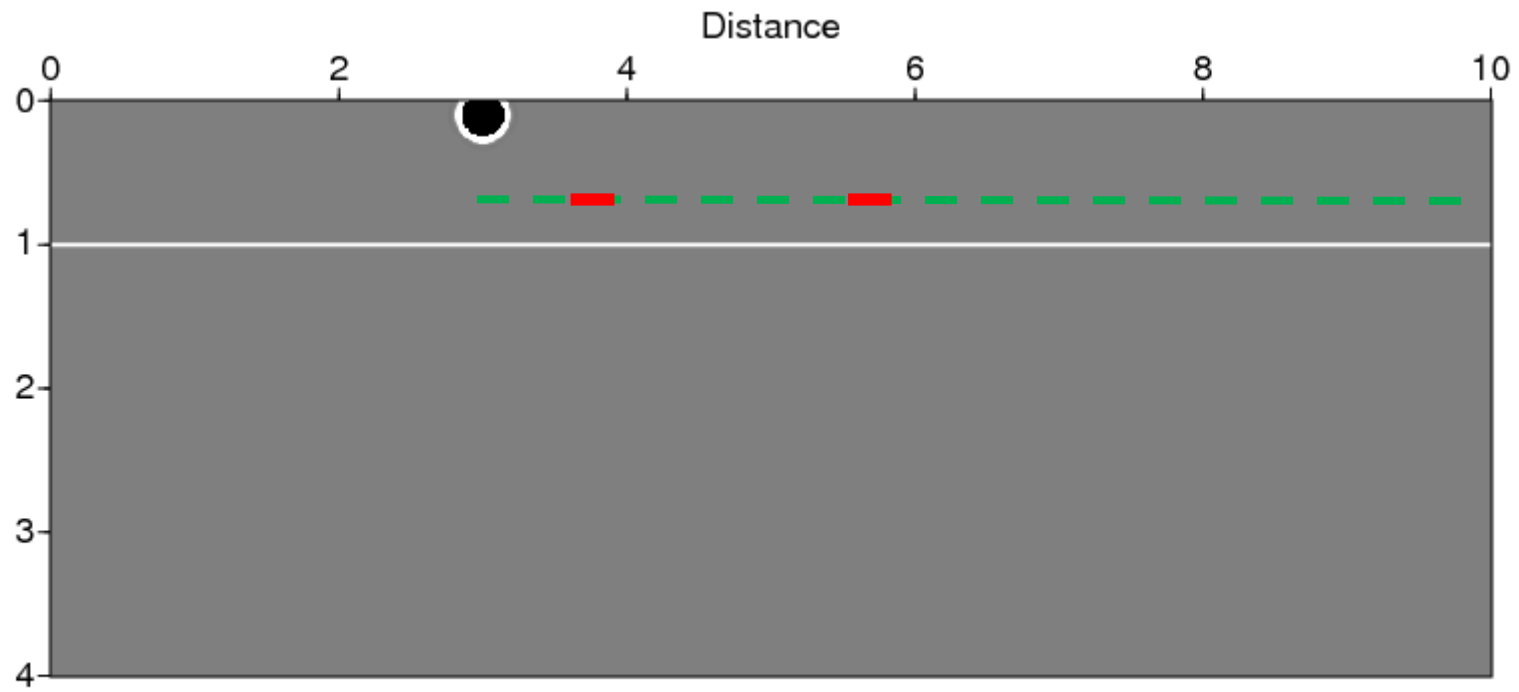

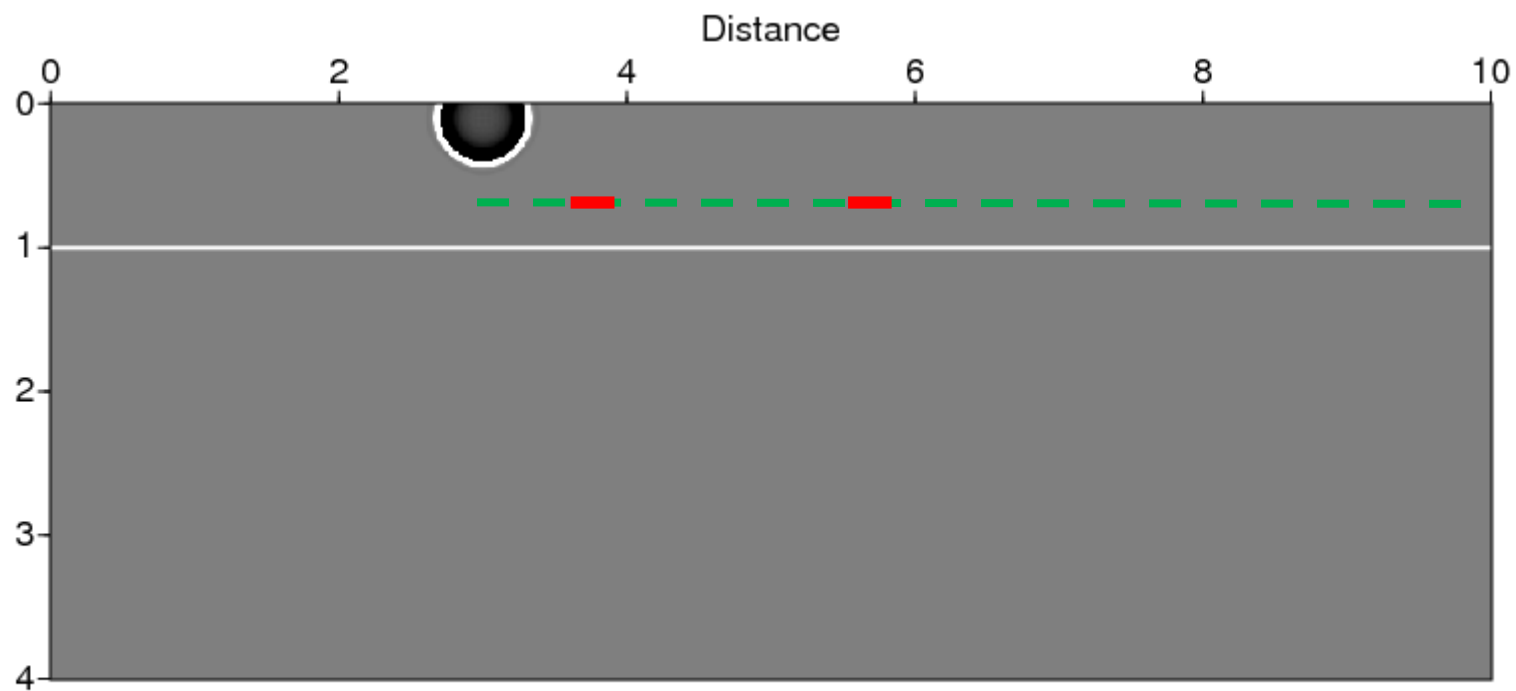

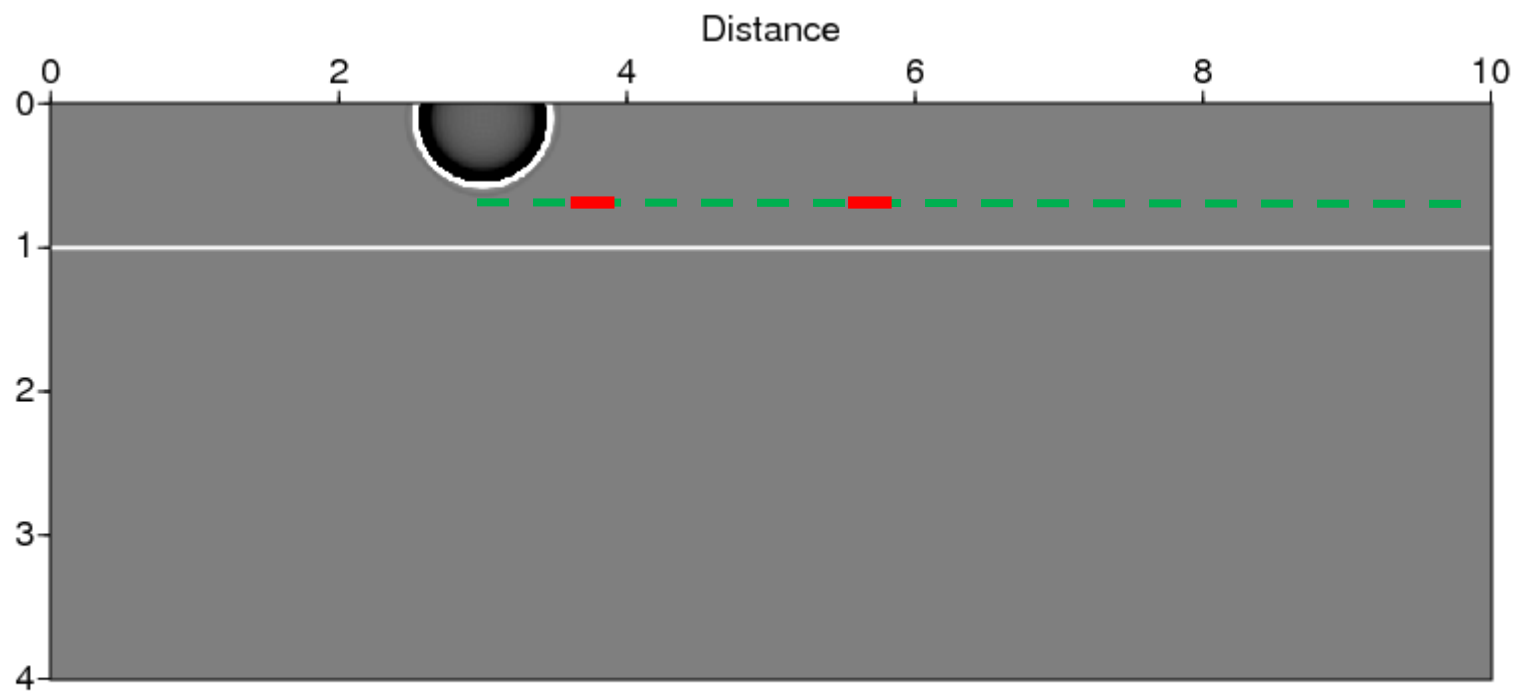

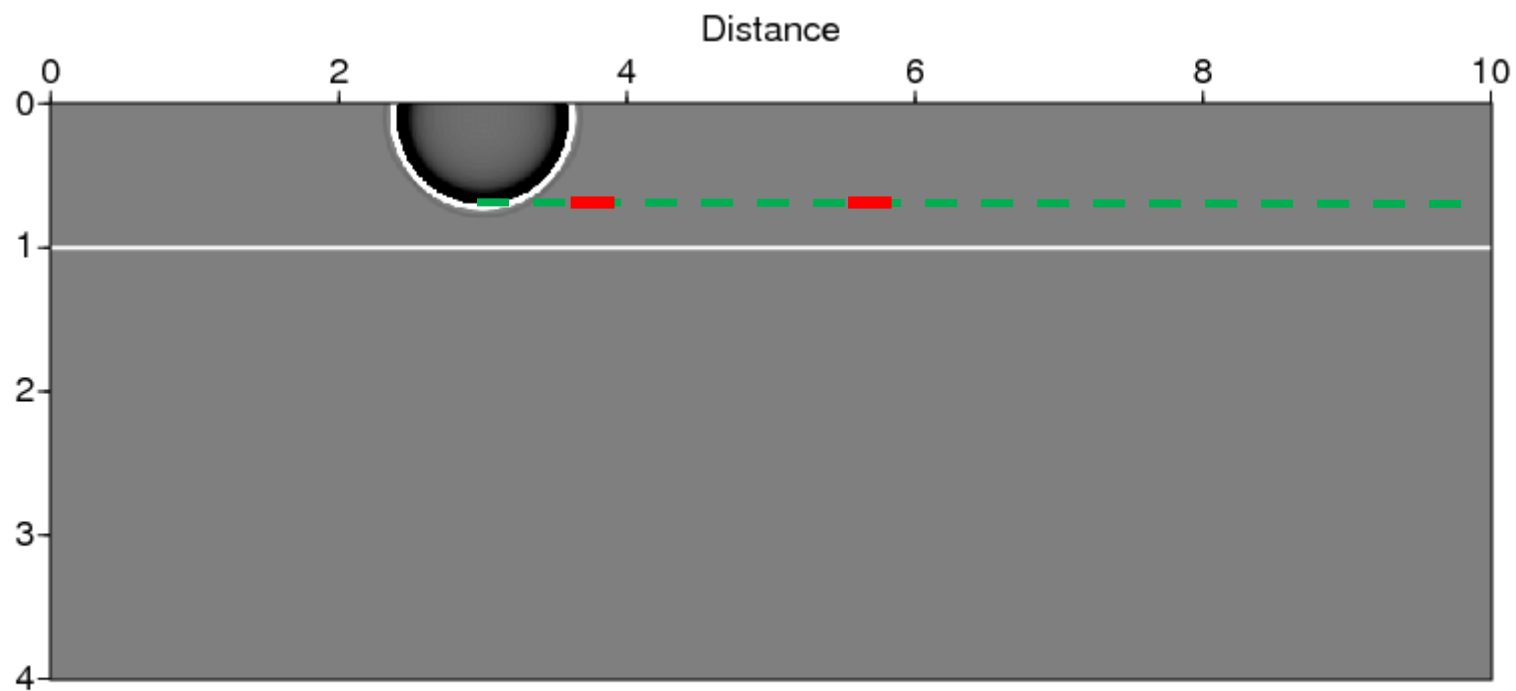

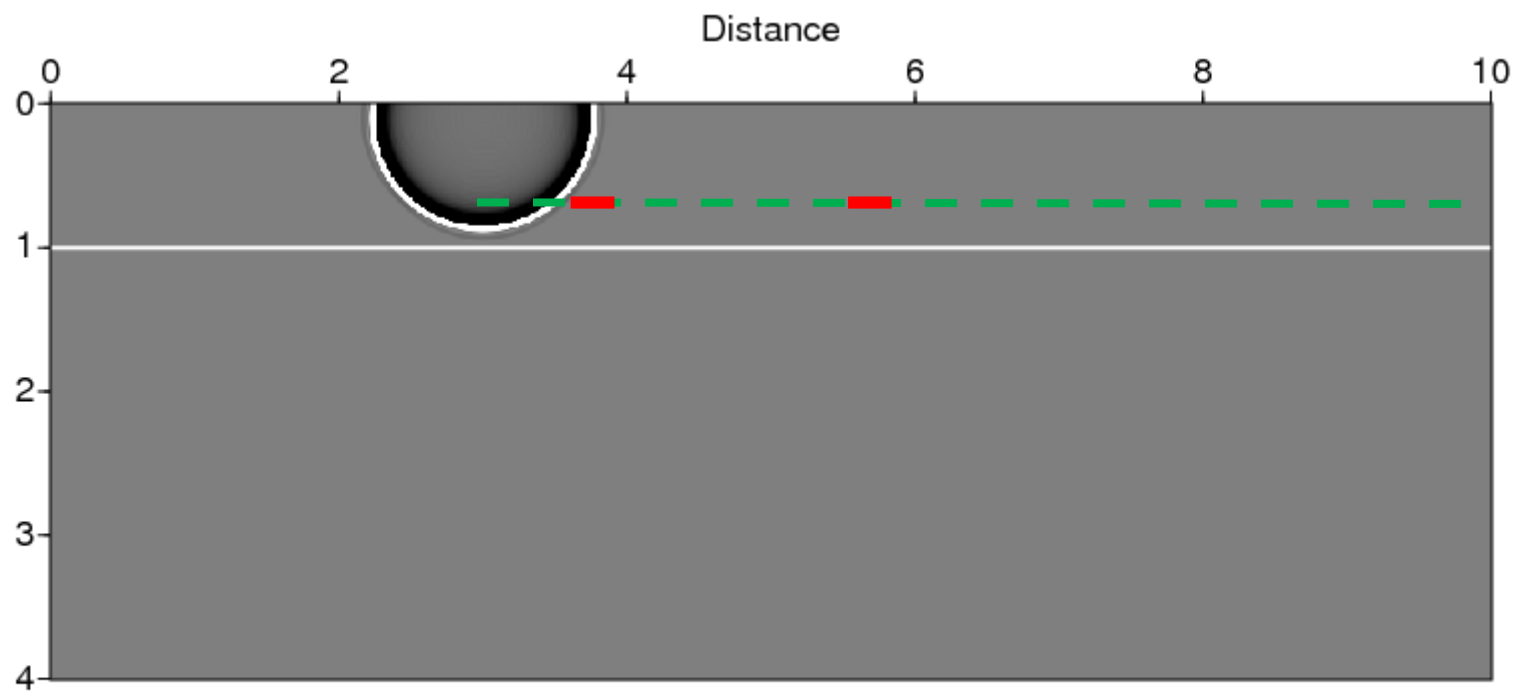

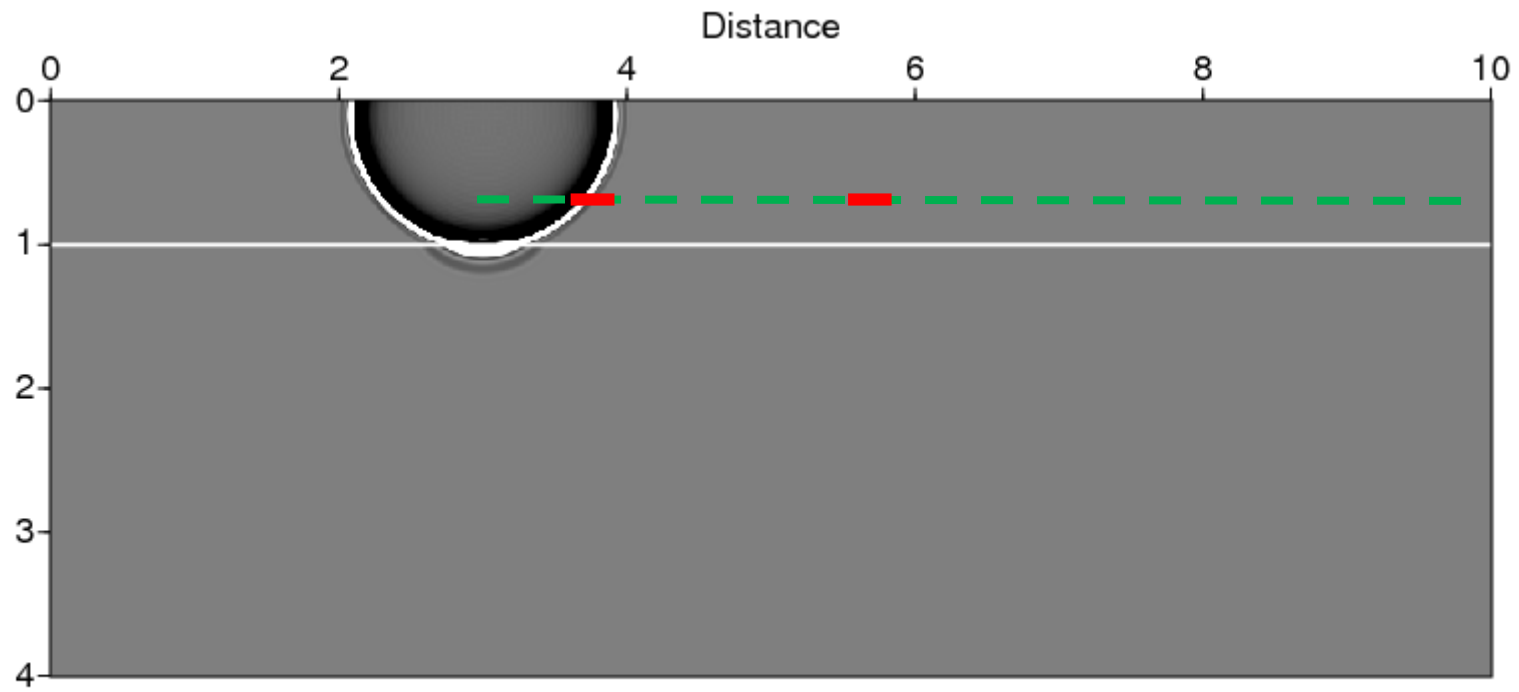

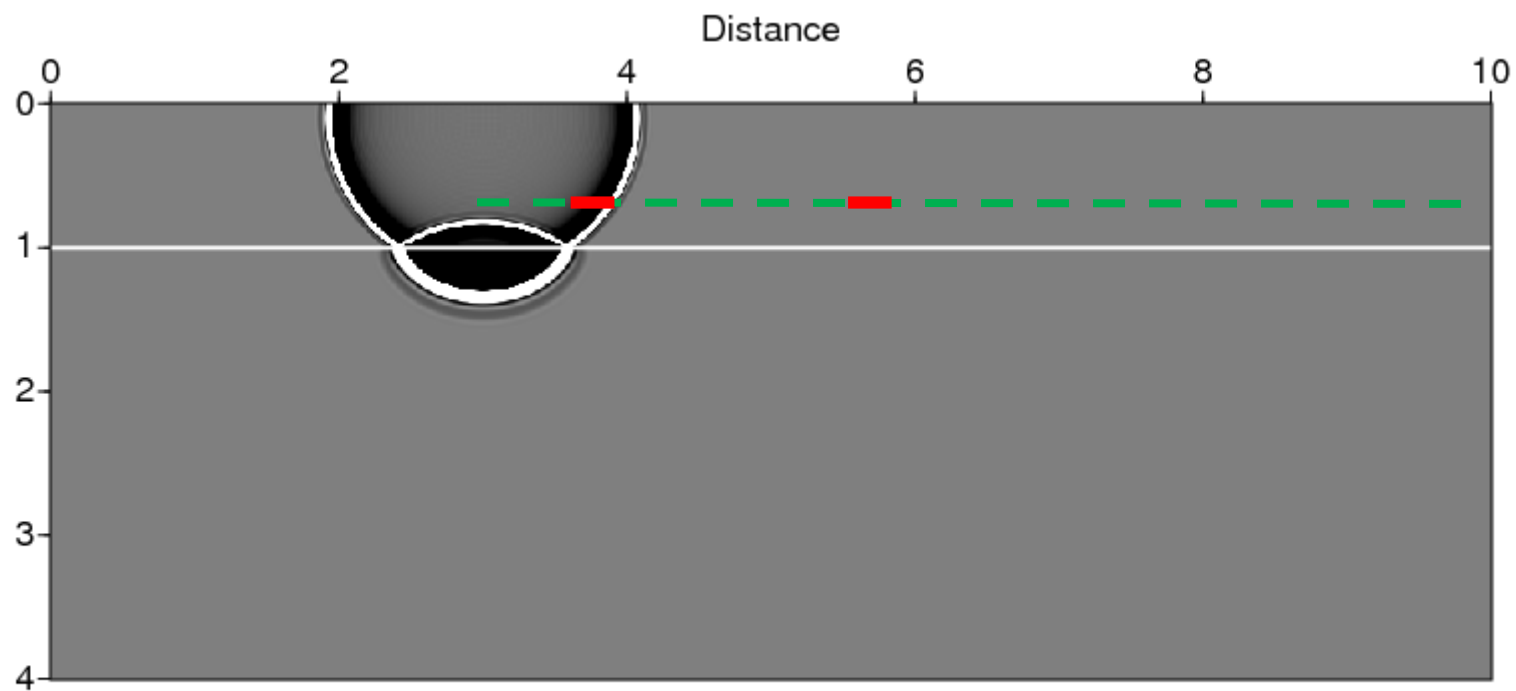

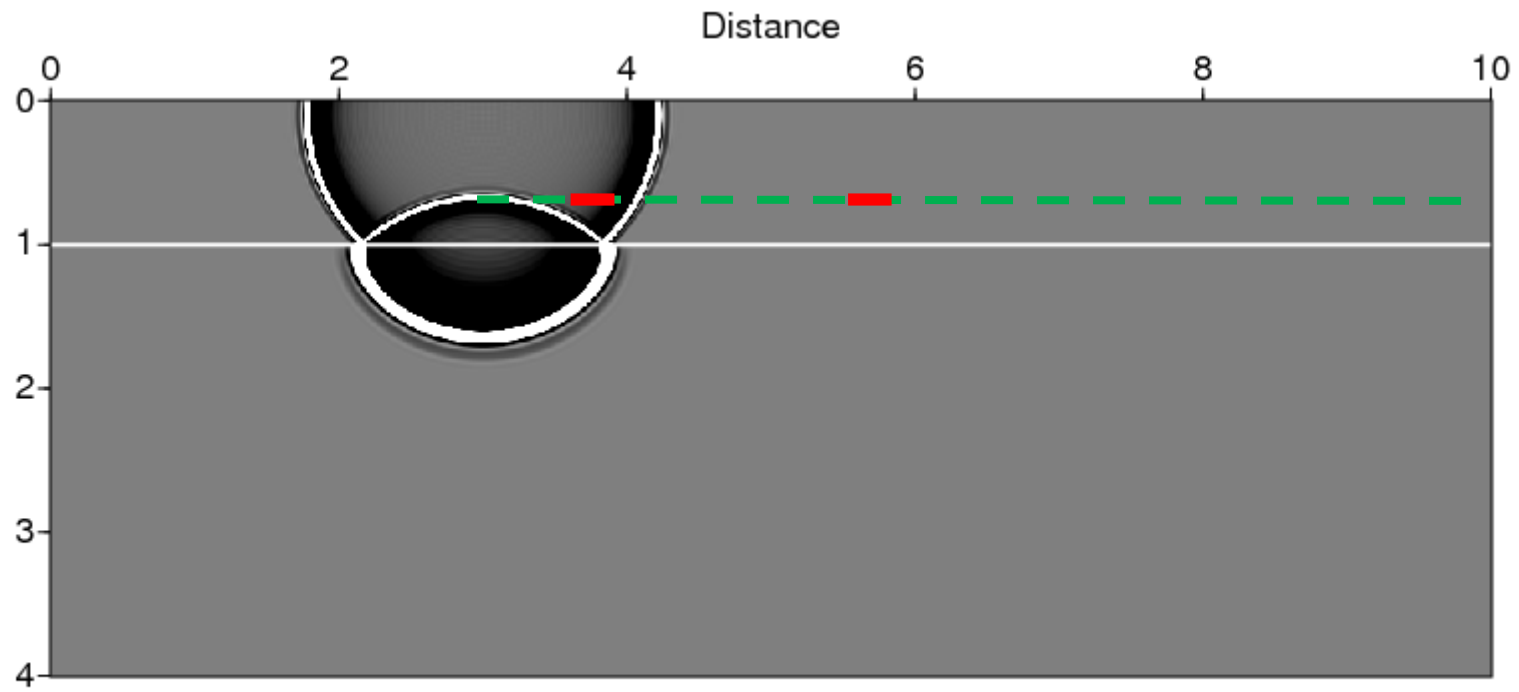

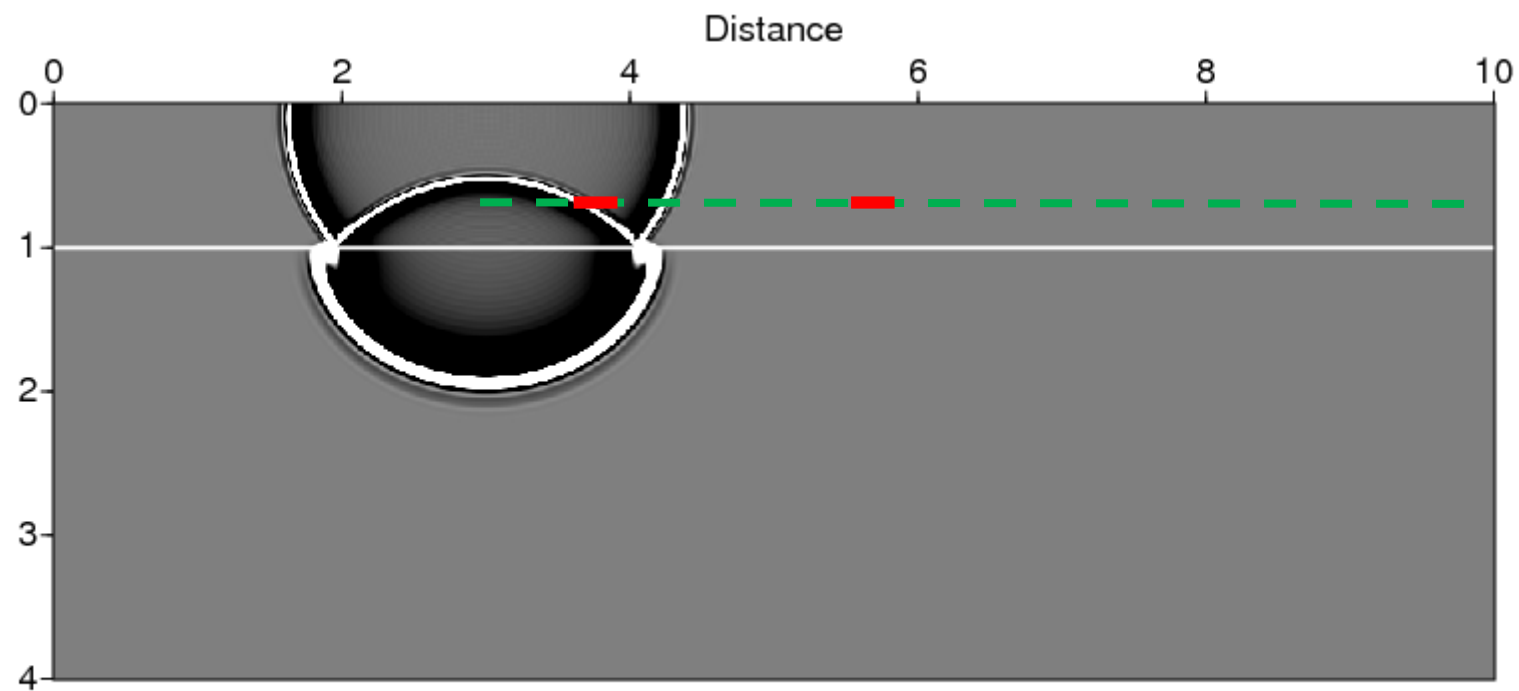

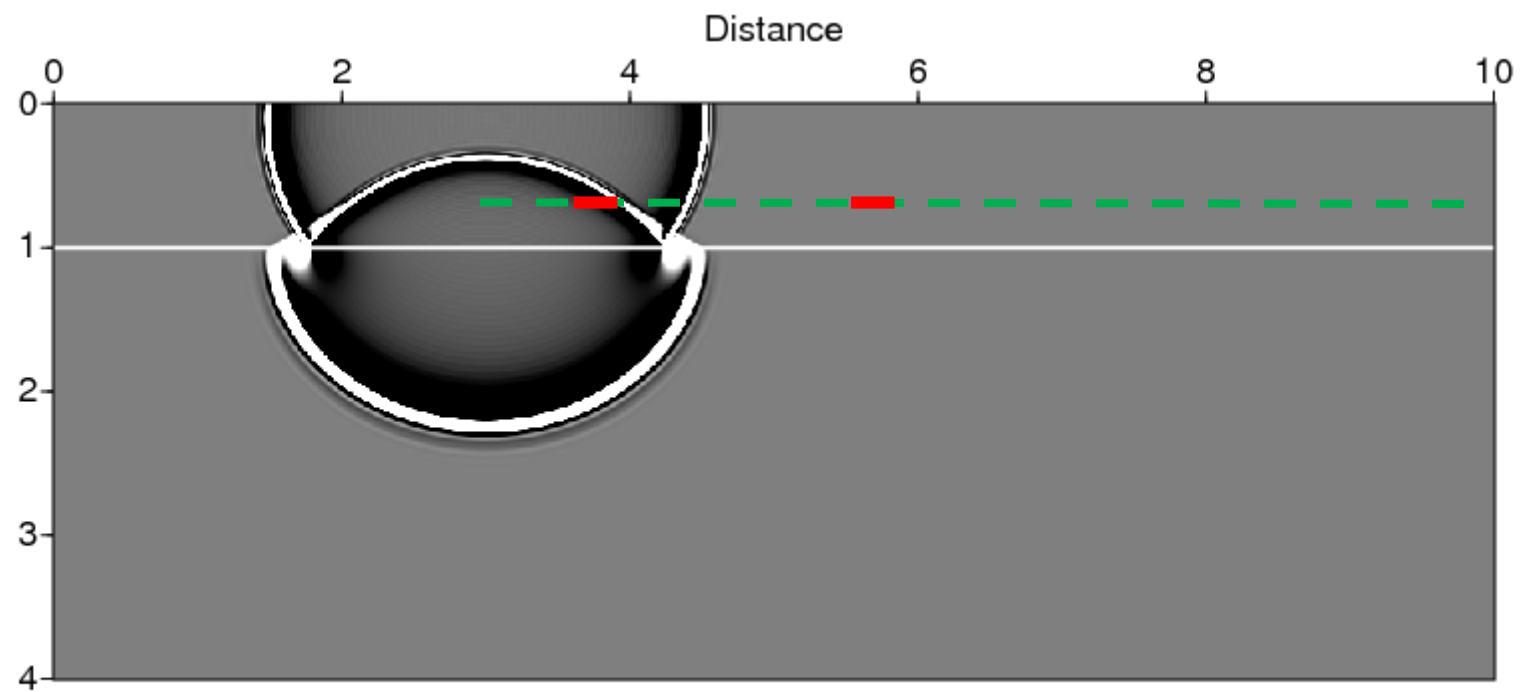

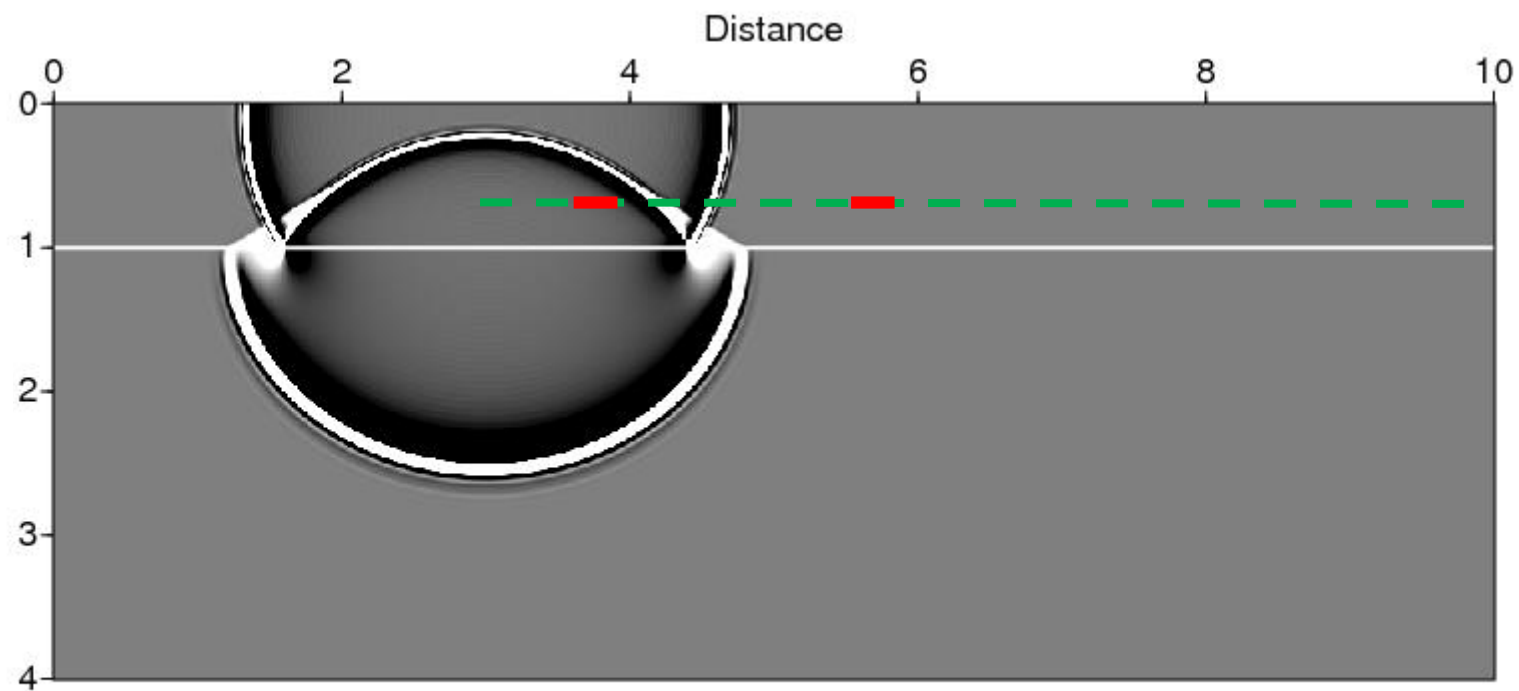

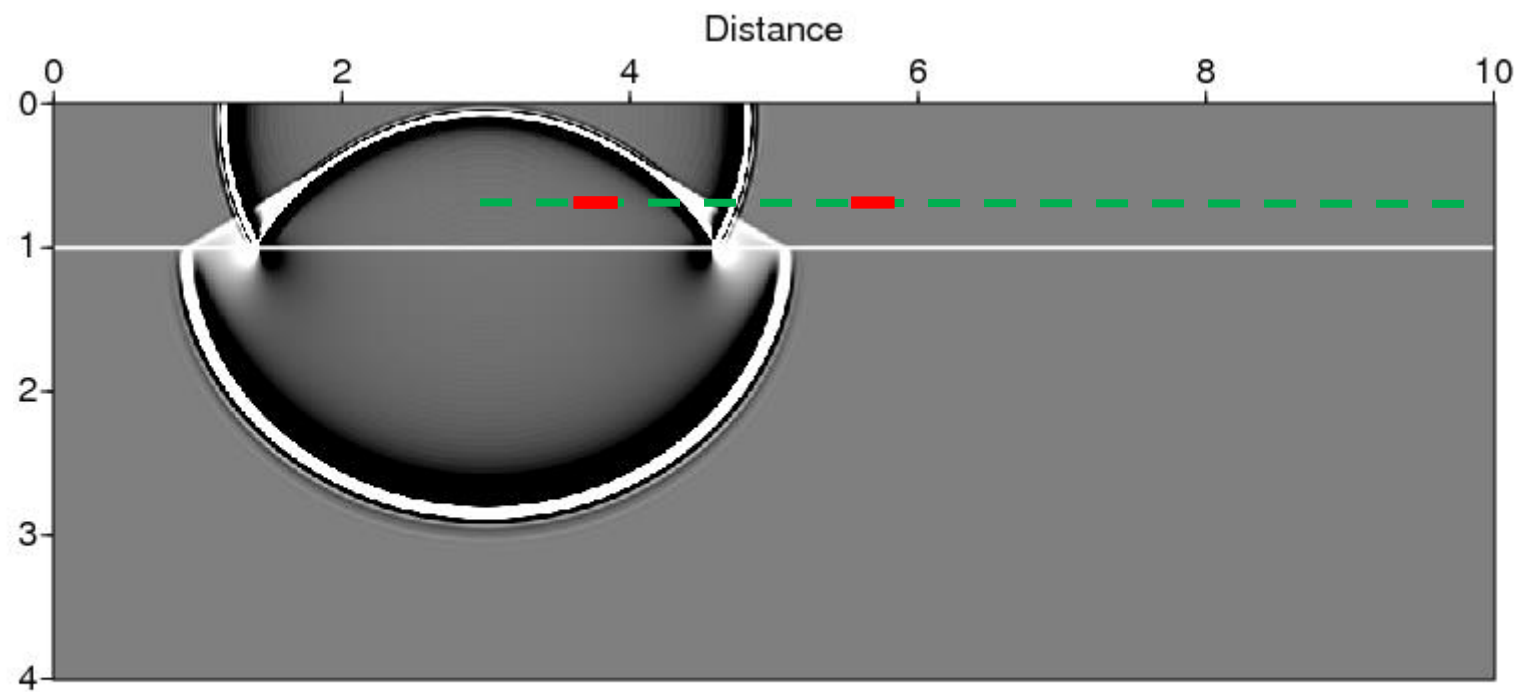

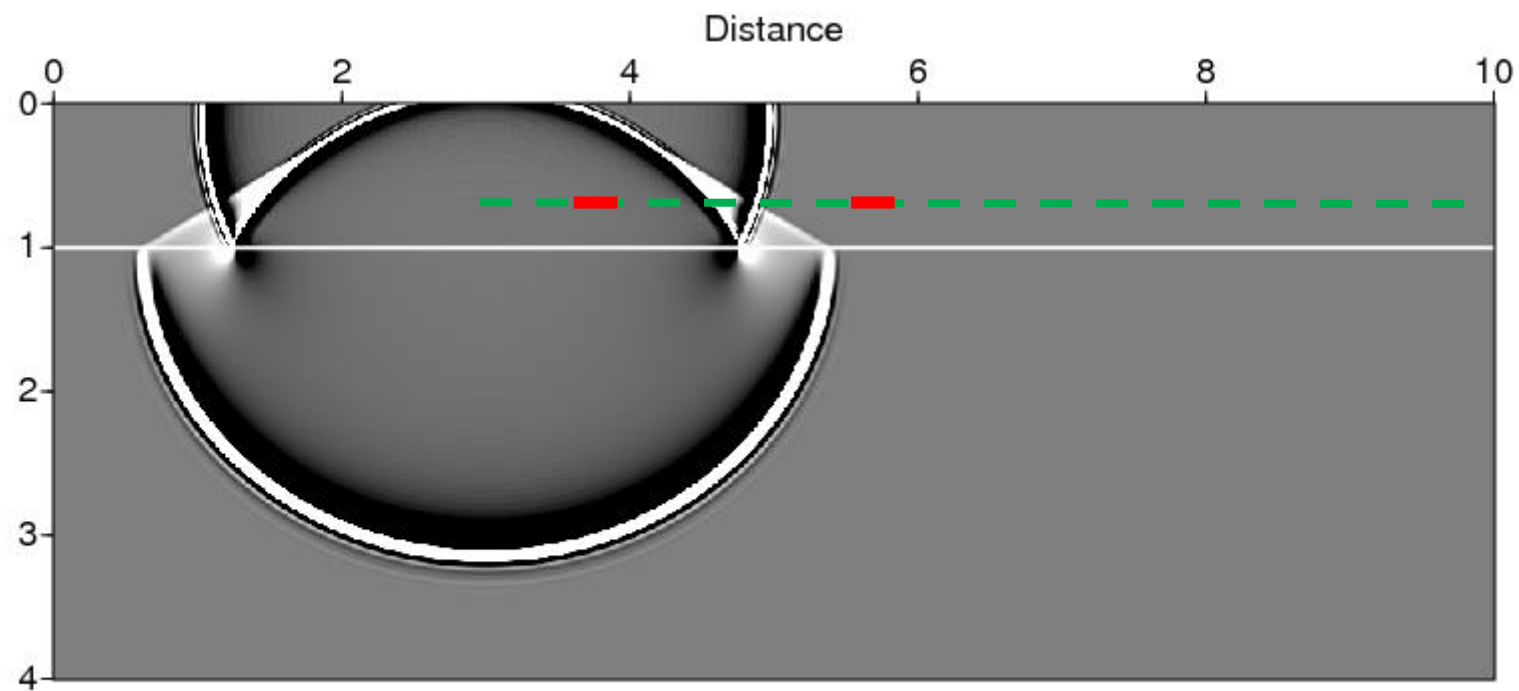

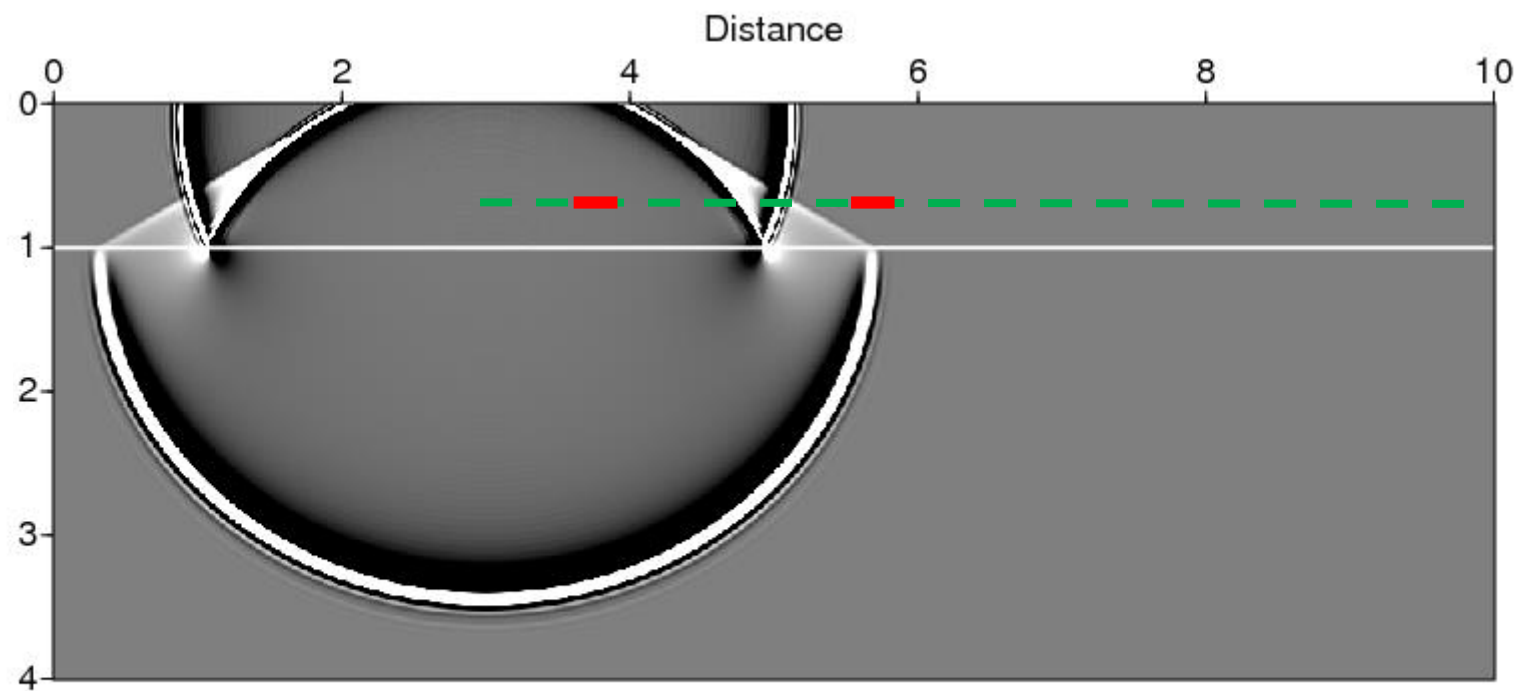

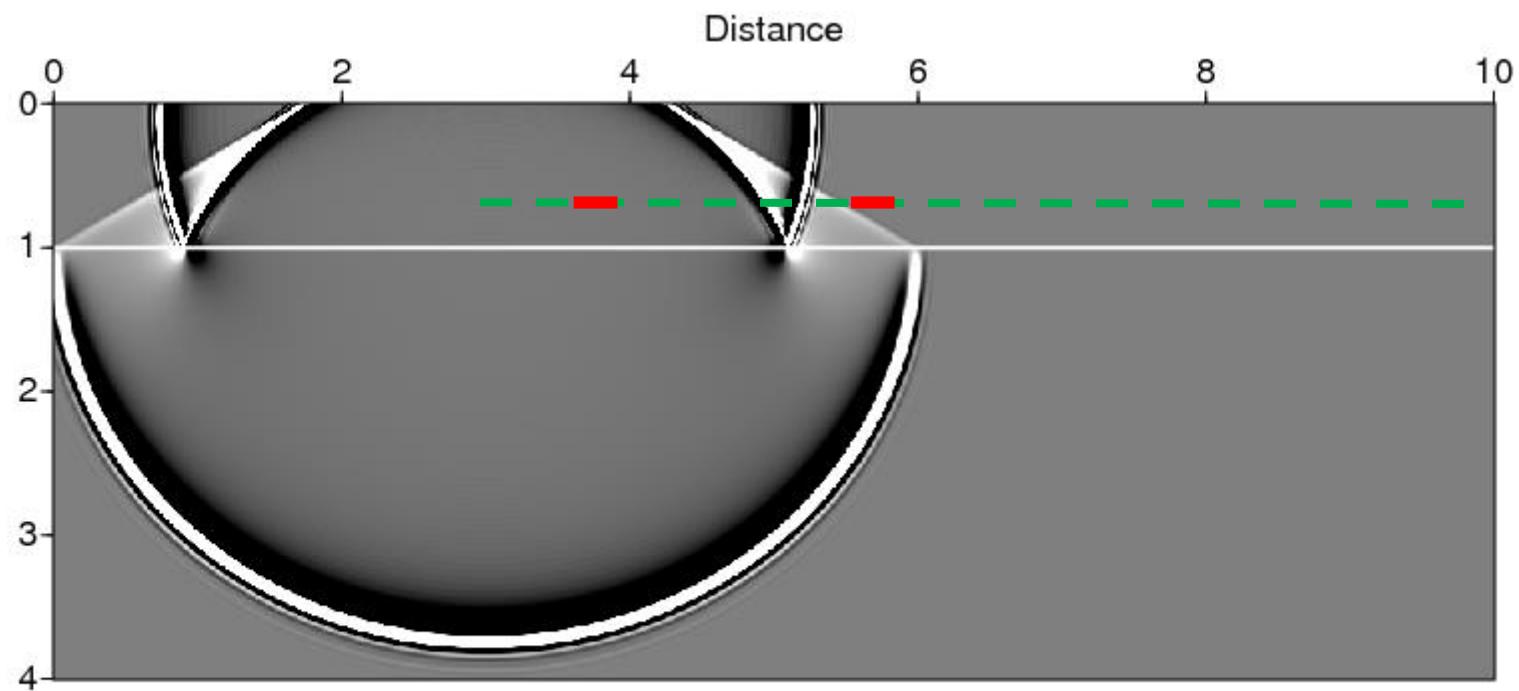

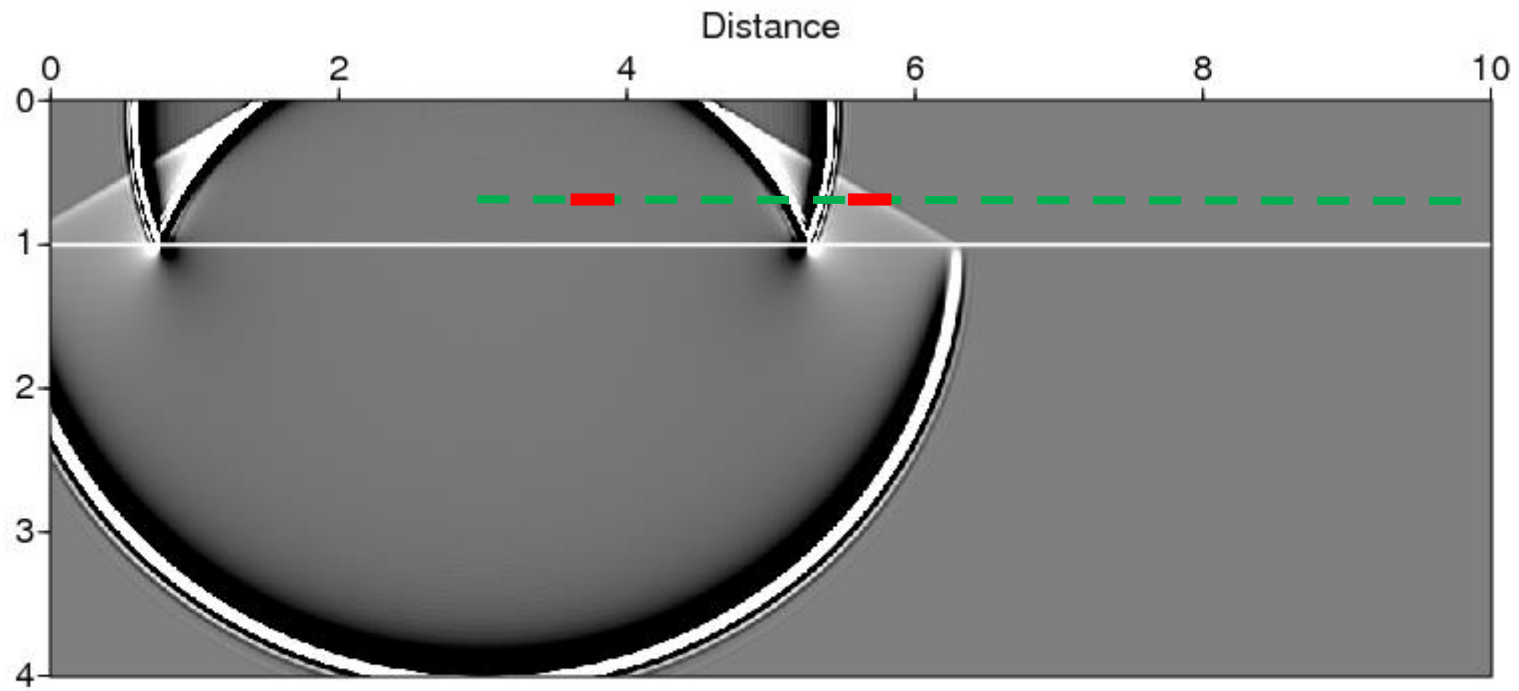

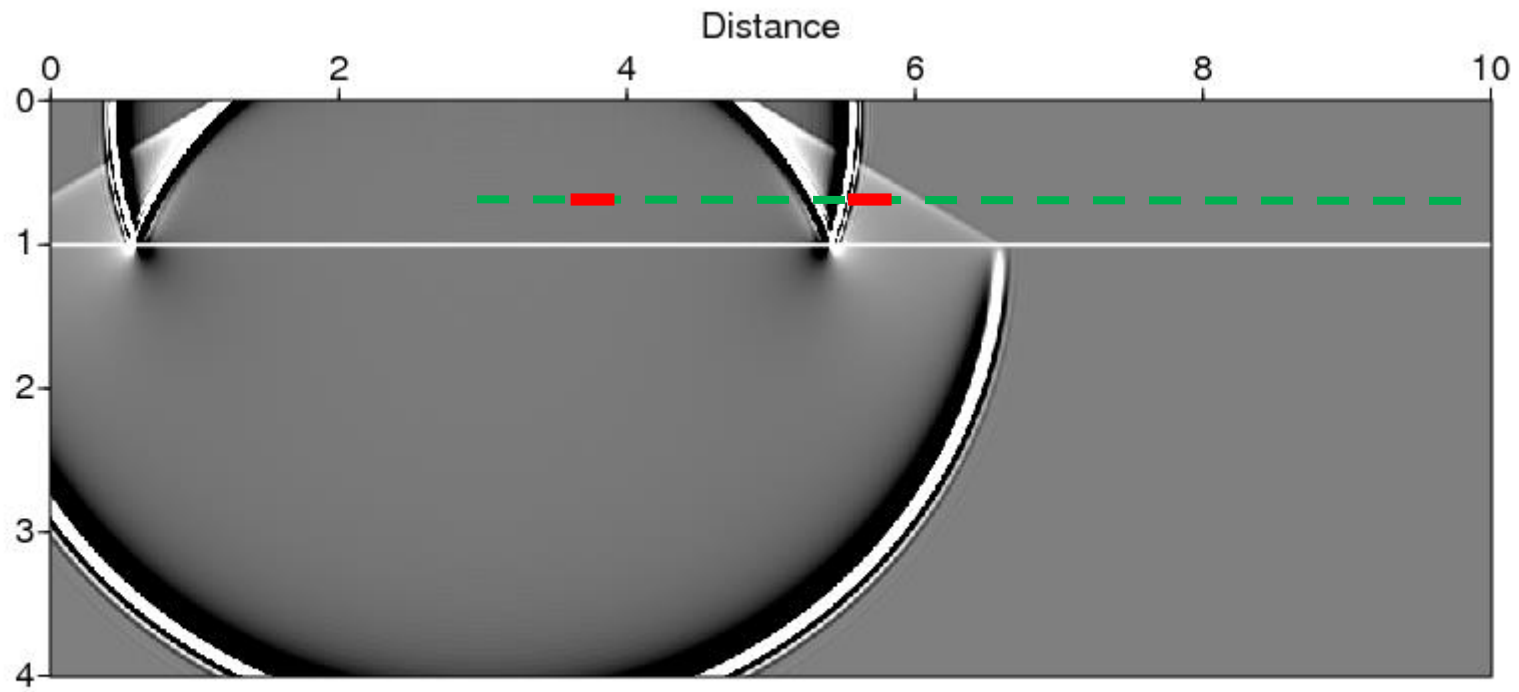

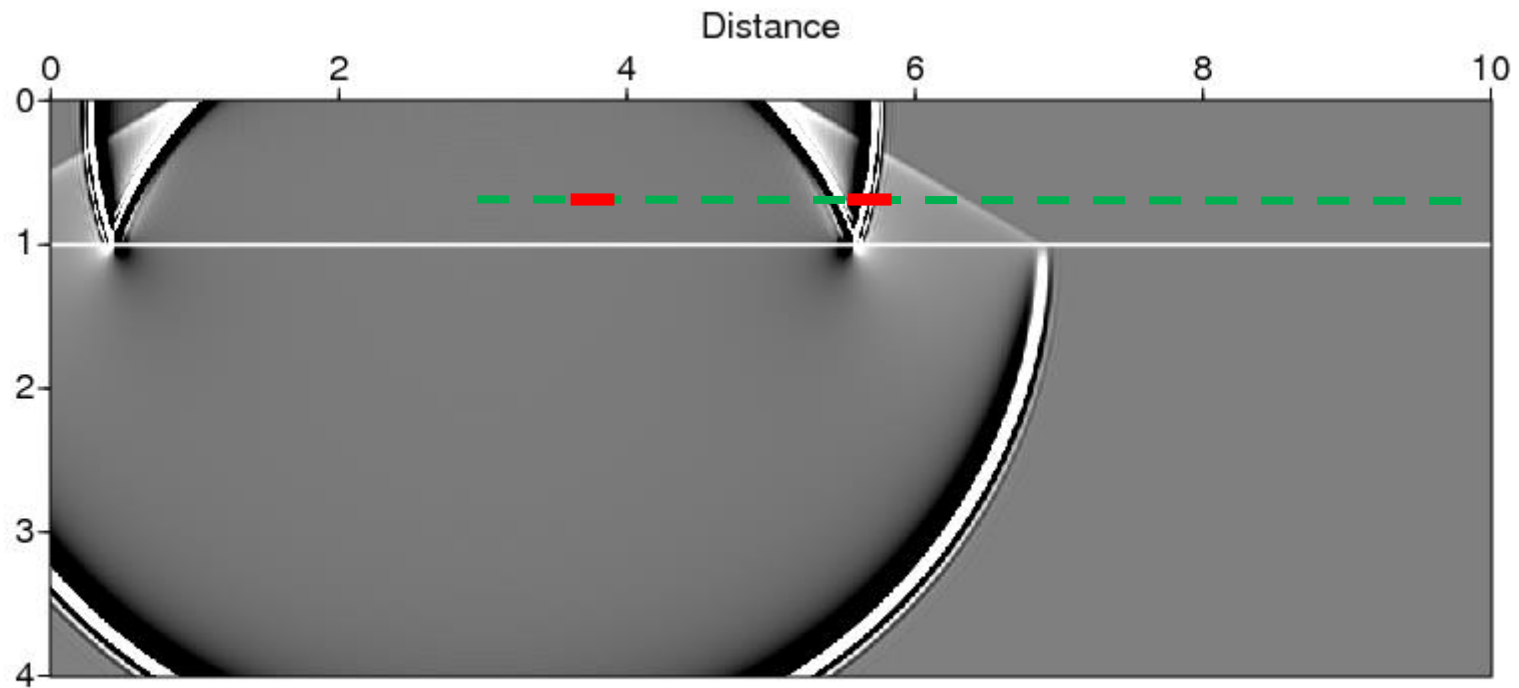

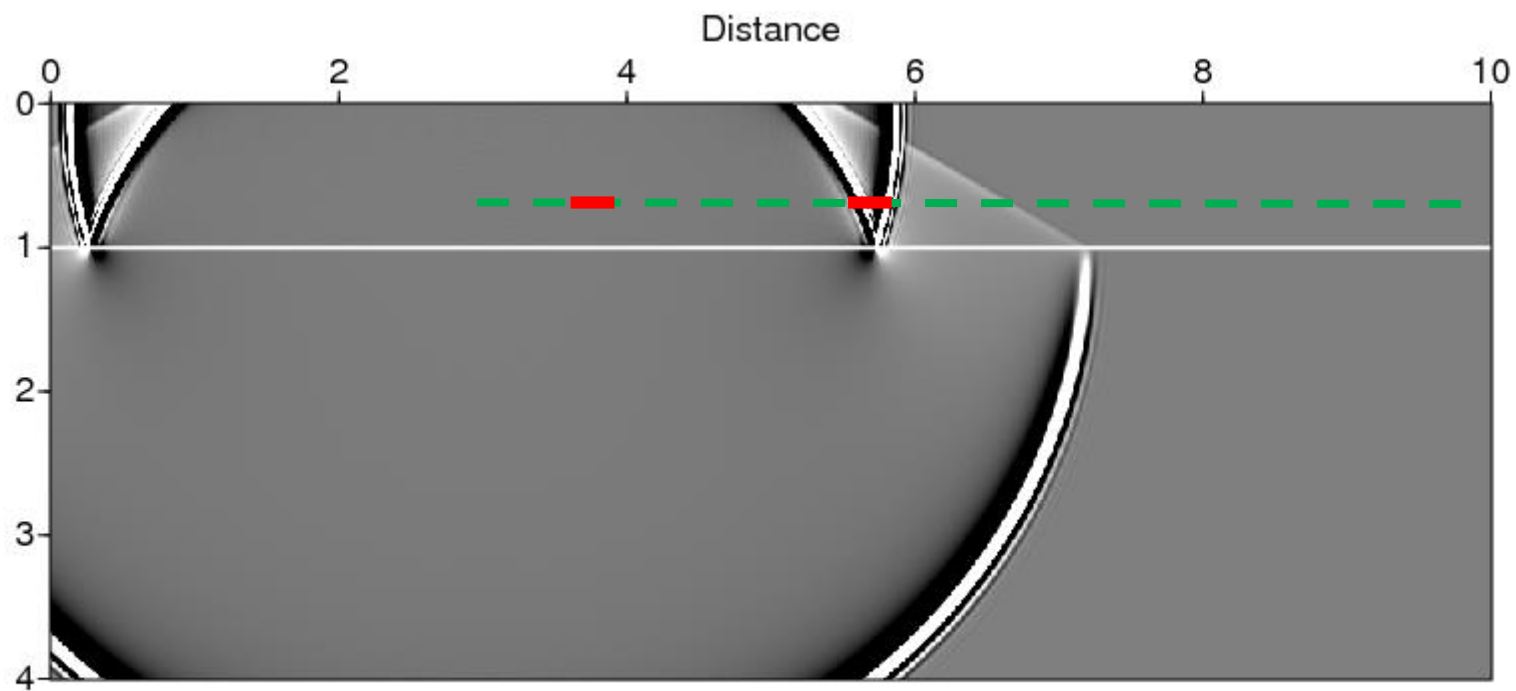

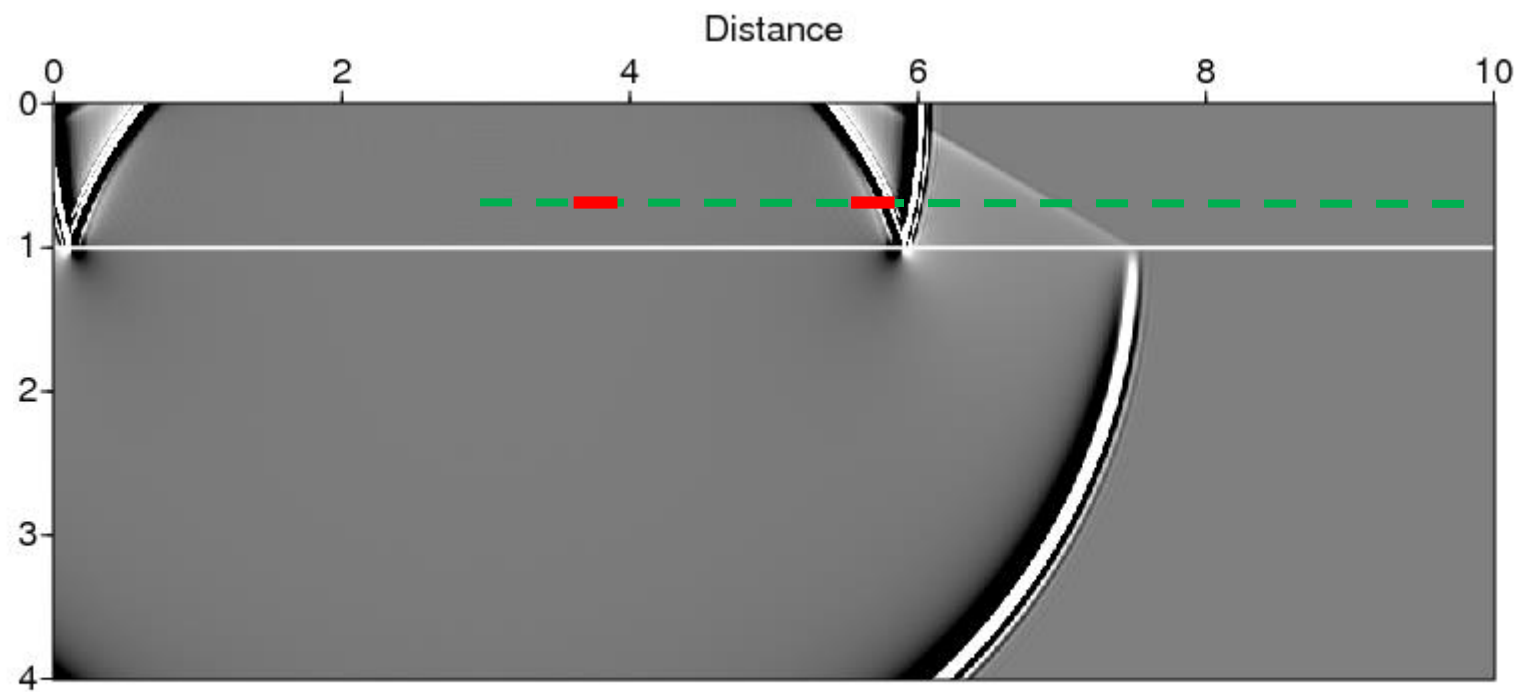

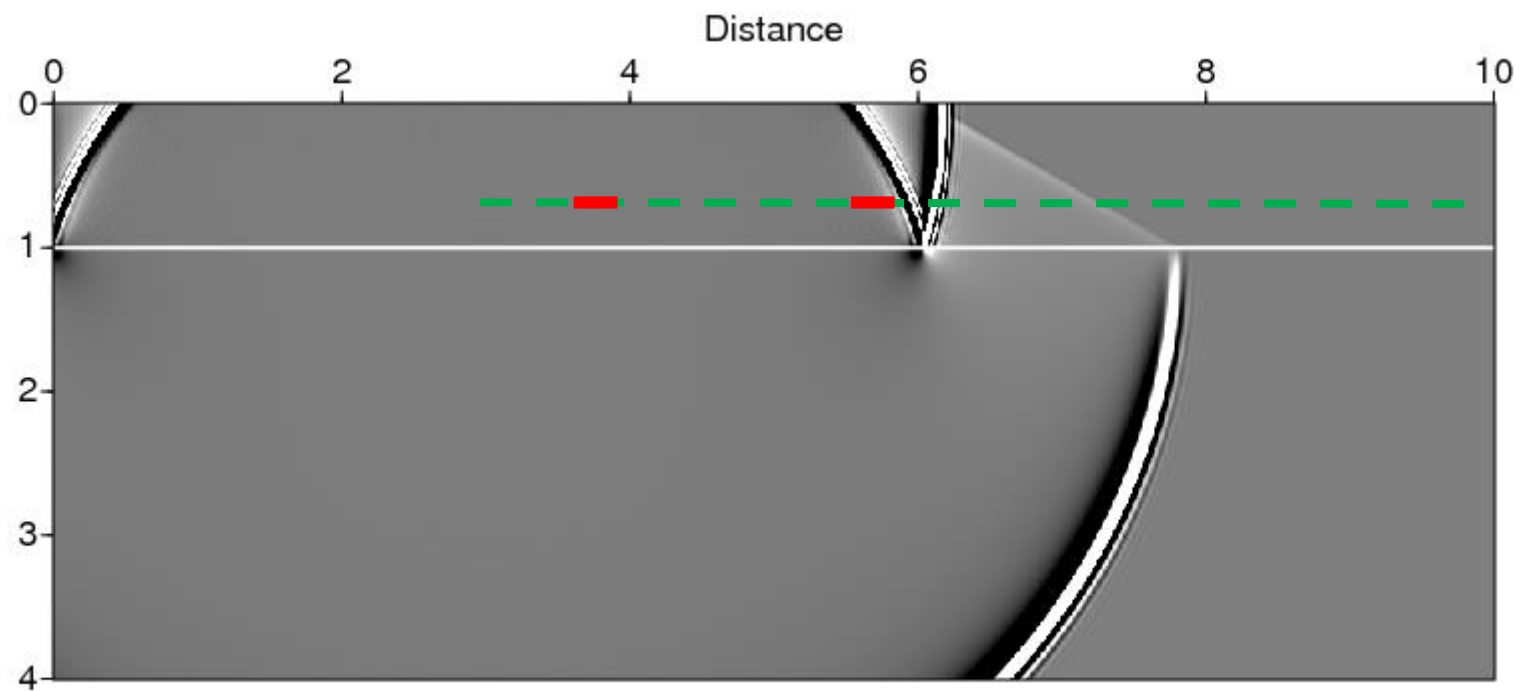

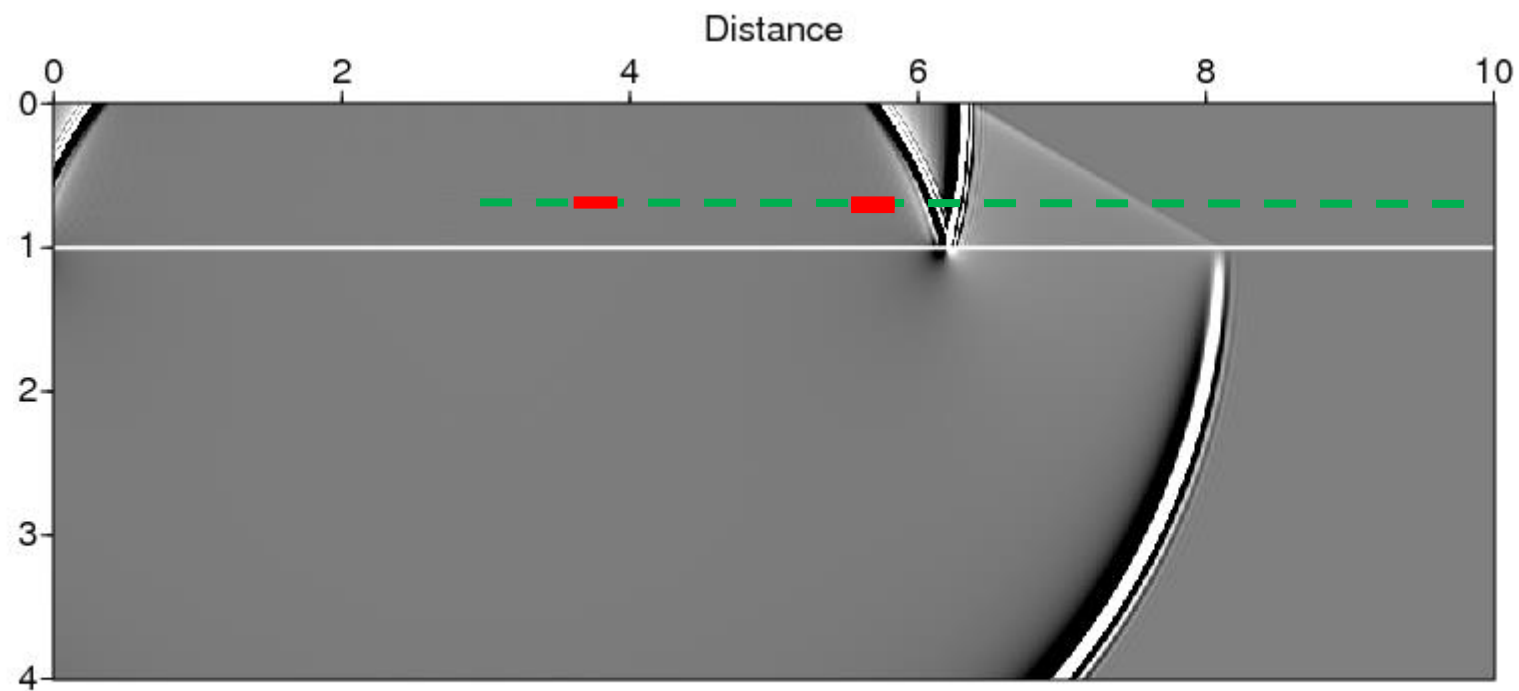

3D acoustic simulation

Waterdepth 2 km

«High velocity» subsurface (2 – 6 km)

Source 40 m above seabed (1.96 km)

Recording at seabed (2 km)

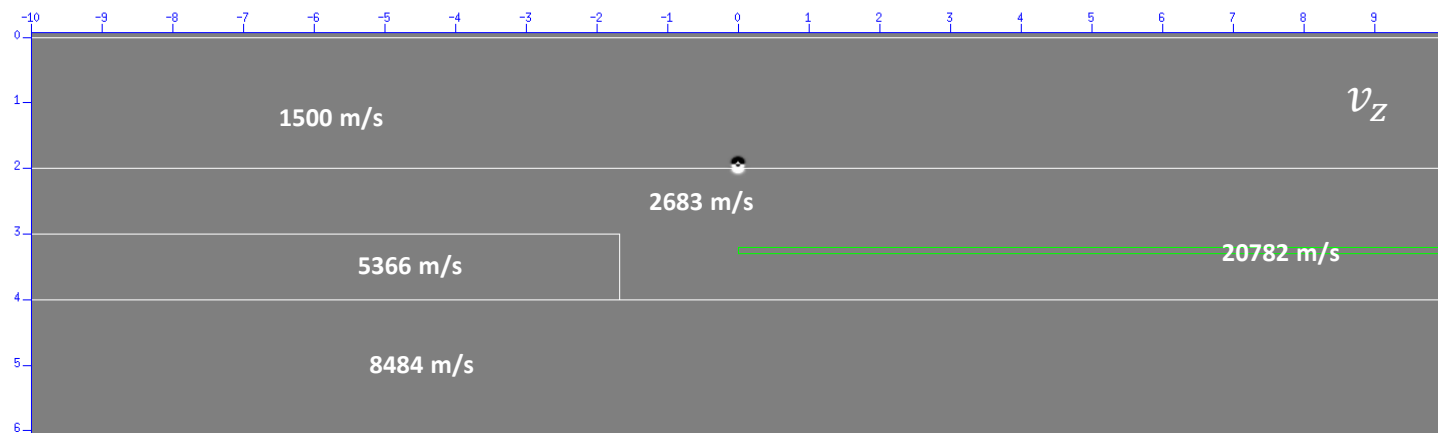

Vertical component of particle velocity

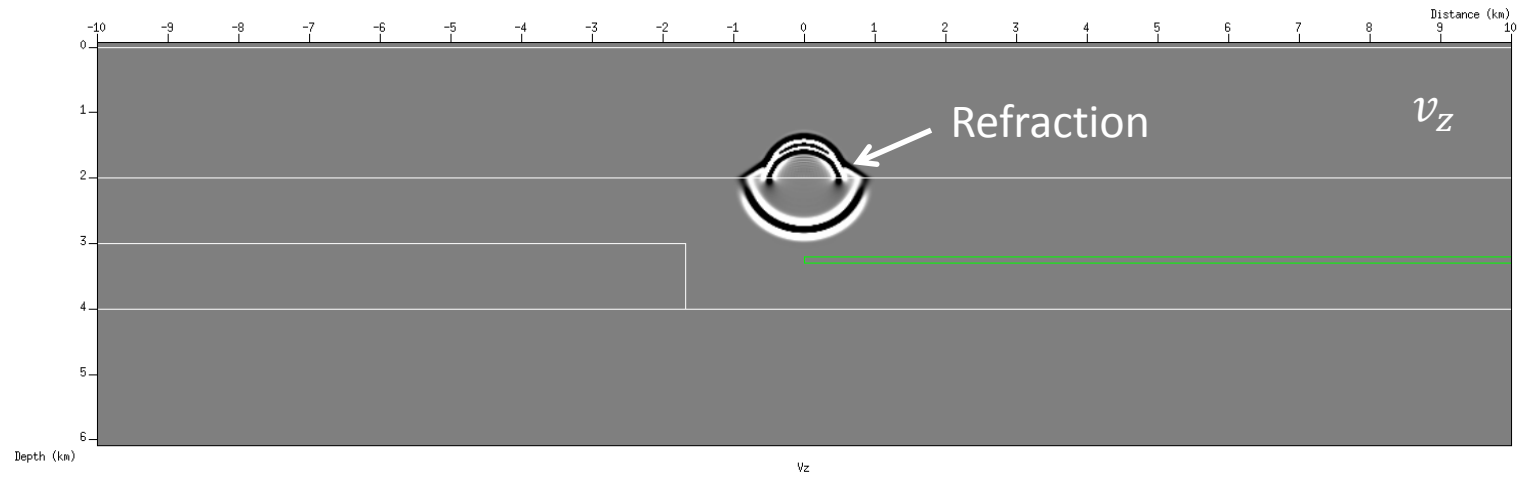

Refraction is first arrival at intermediate and large offset.

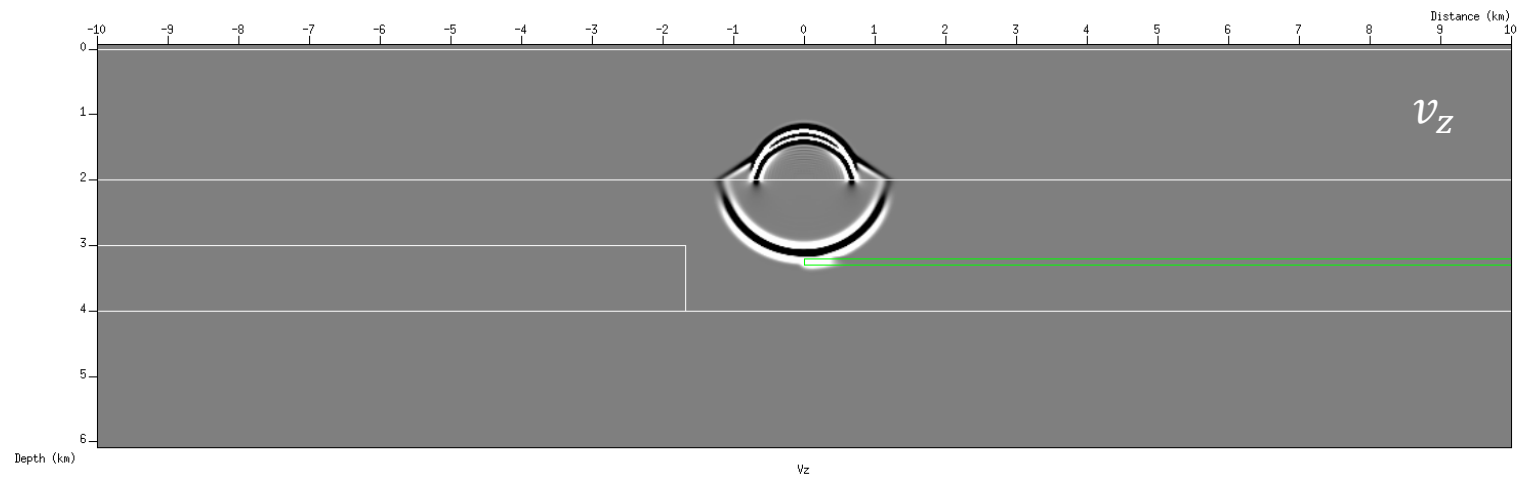

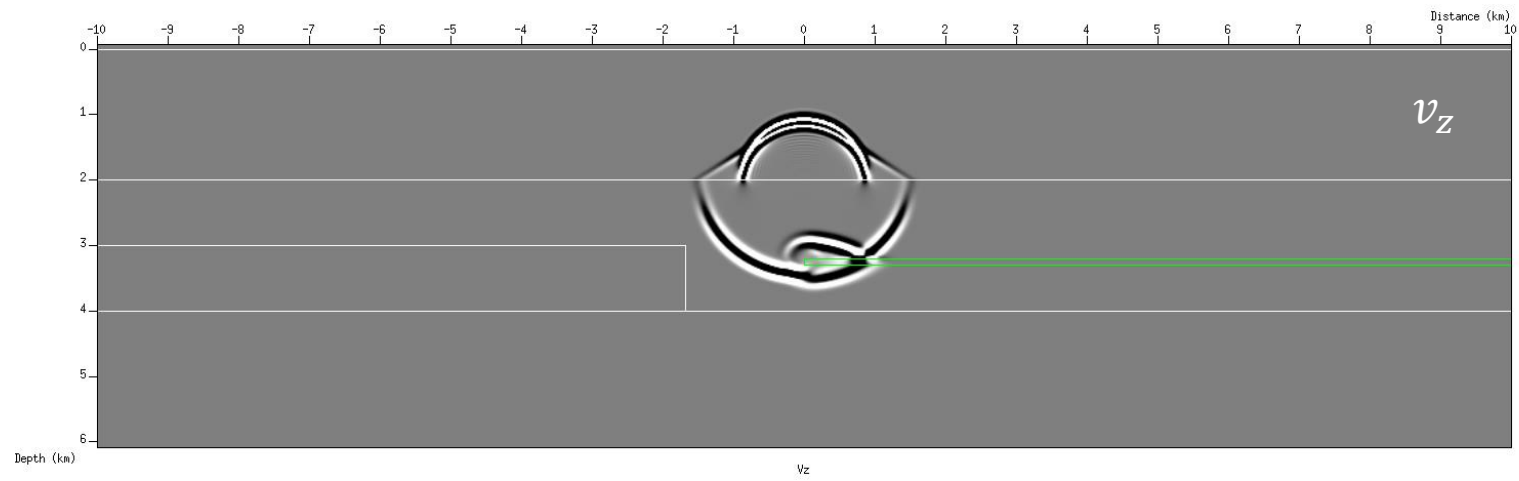

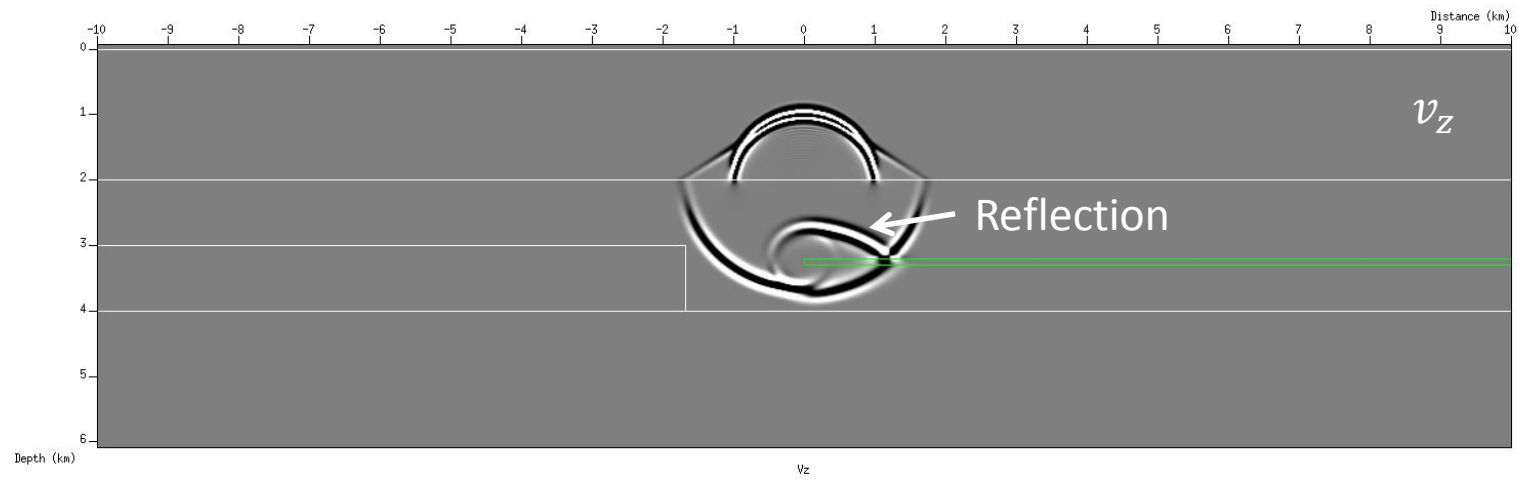

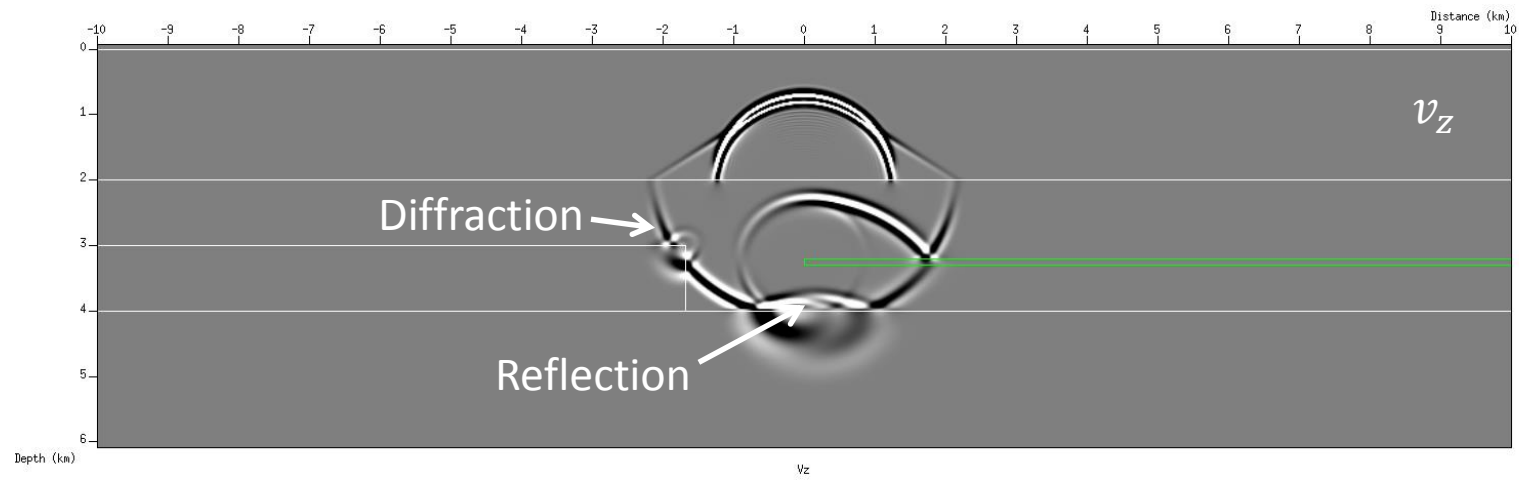

A CSEM - seismic comparison

Seabed seismic nodes

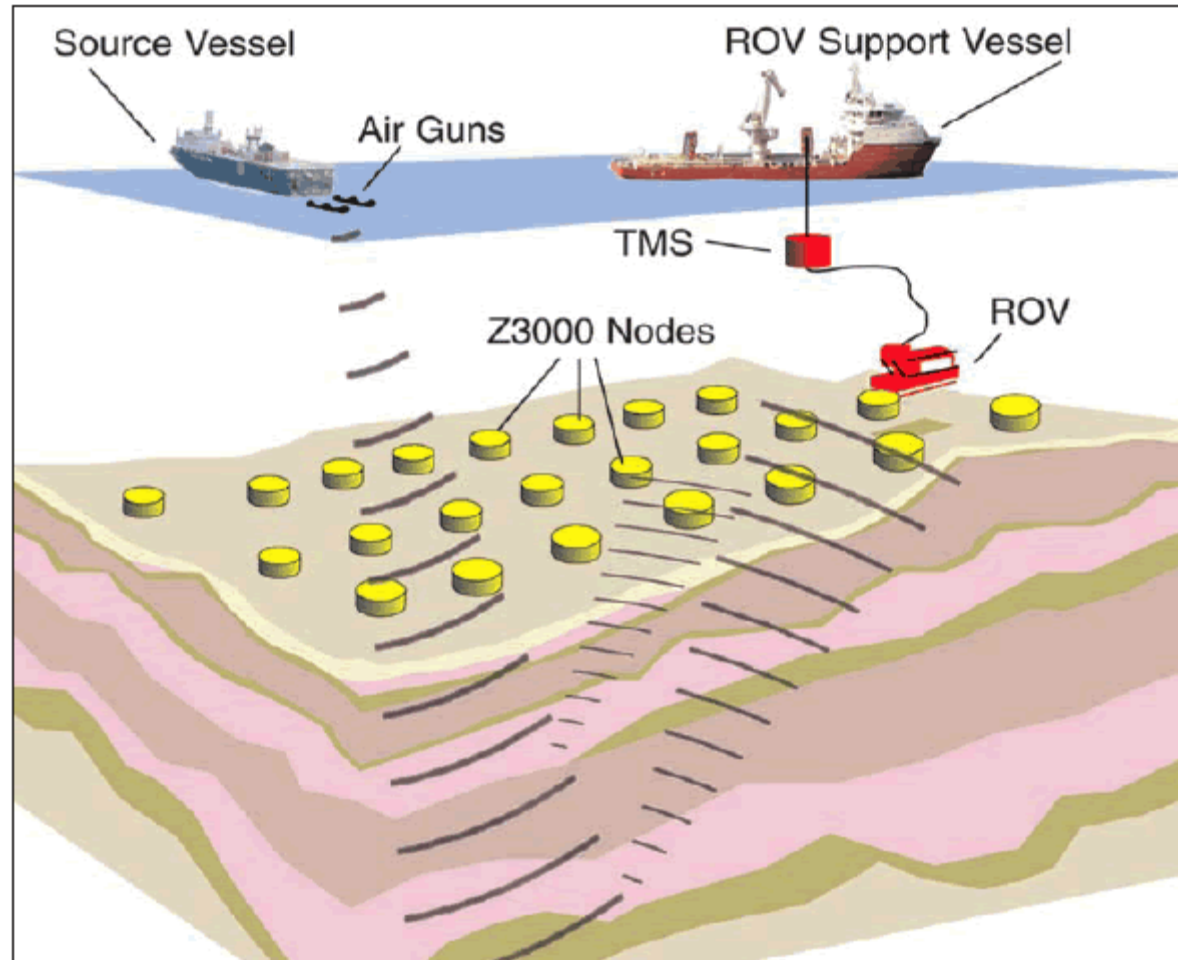

Record particle-velocity vector and pressure

$v_z(x, t)$

$v_x(x, t)$

$v_y(x, t)$

$P(x, t)$

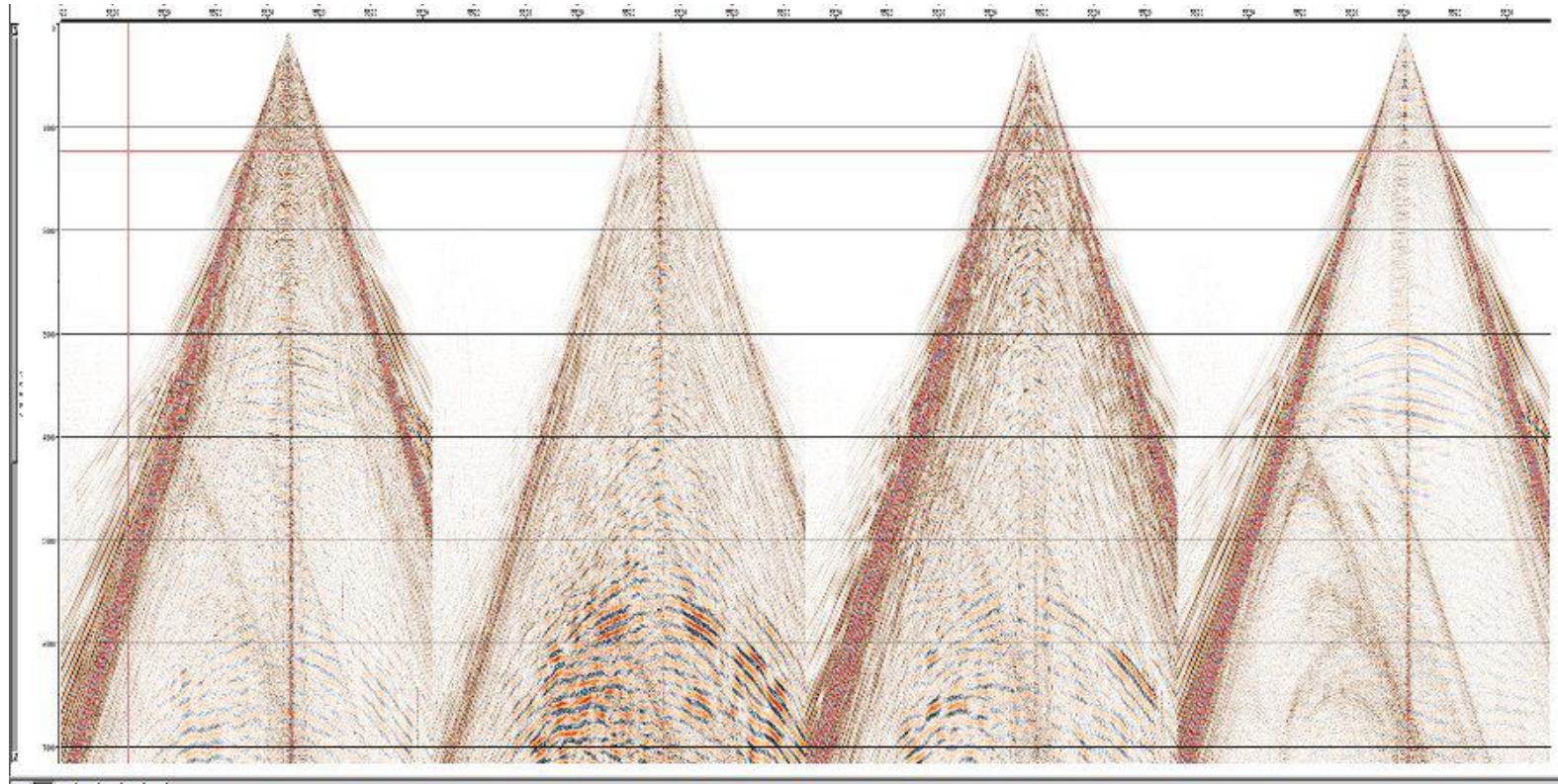

Interpretation of seismic data

Basic concepts:

- Reflection
- Transmission
- Refraction
- Diffraction
- Rays
- Wavefronts

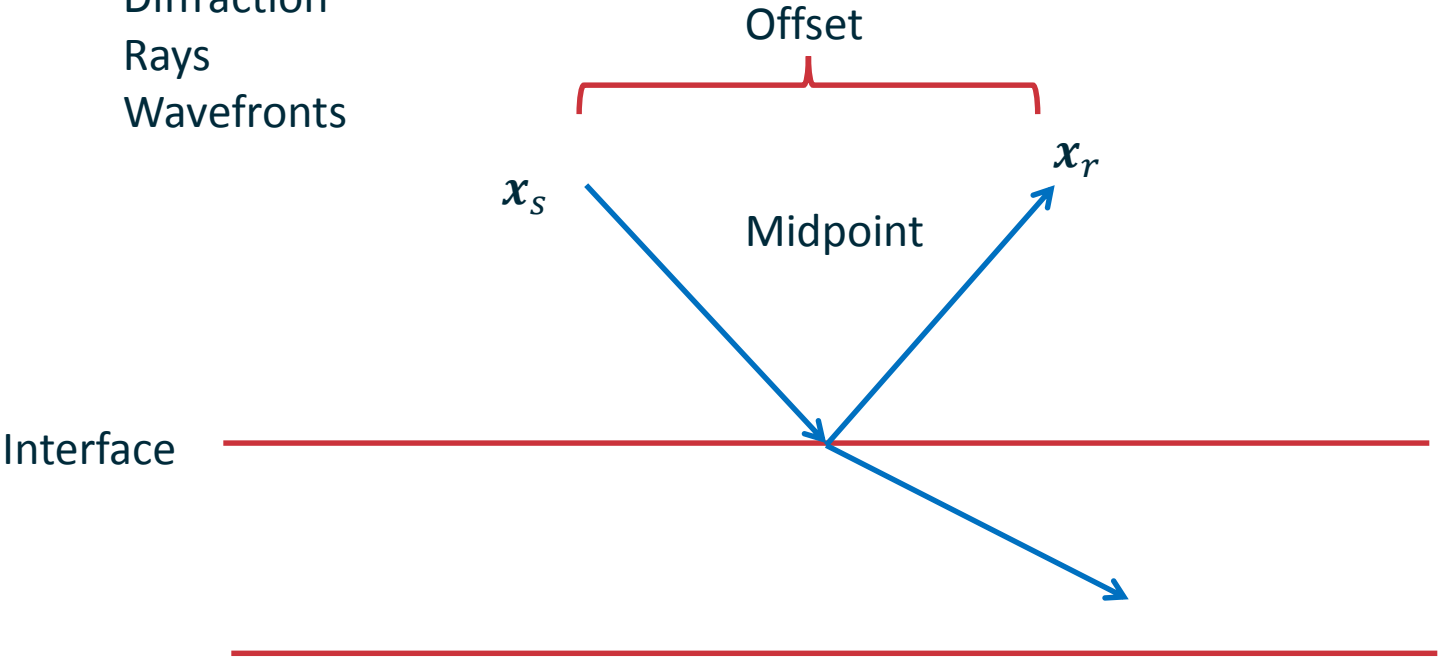

Refraction: At some offset the refracted wave arrives before the reflection.
Requires that velocity increase with depth.

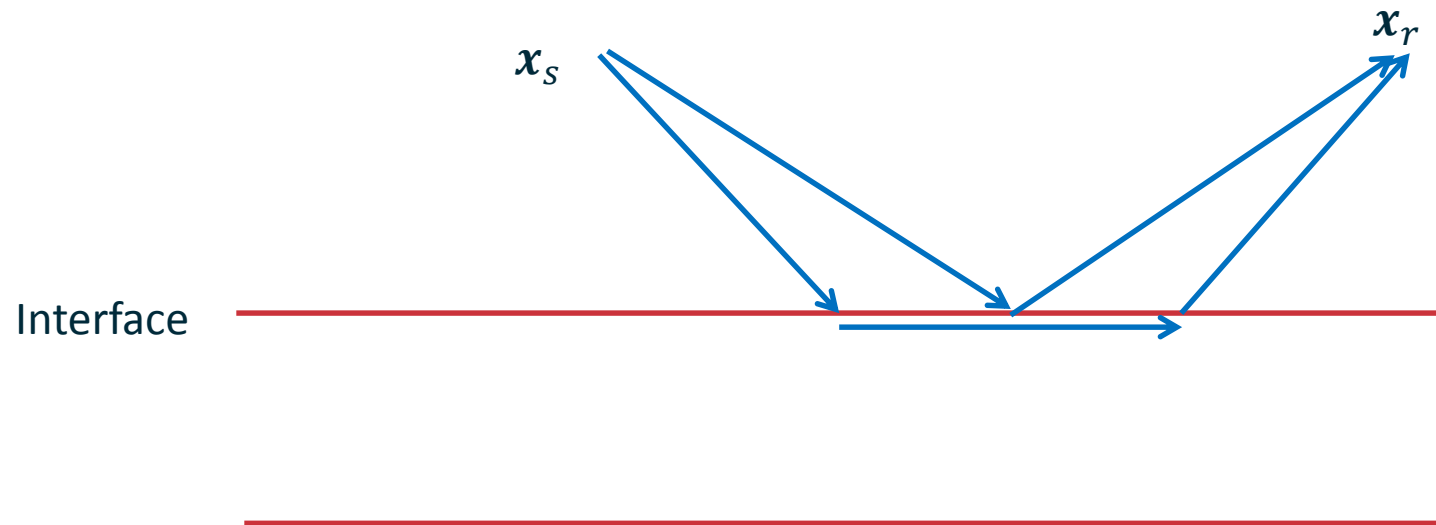

Basic concepts:

Reflection

Transmission

Refraction

Diffraction

Rays

Wavefronts

Are similar concepts applicable for the interpretation of low-frequency propagation of electromagnetic fields?

3D CSEM

Source: Electric dipole ~ 40 m above seabed

Receivers: Voltmeters and coils at the seabed

Typical frequency range: 0.1 Hz – 5Hz

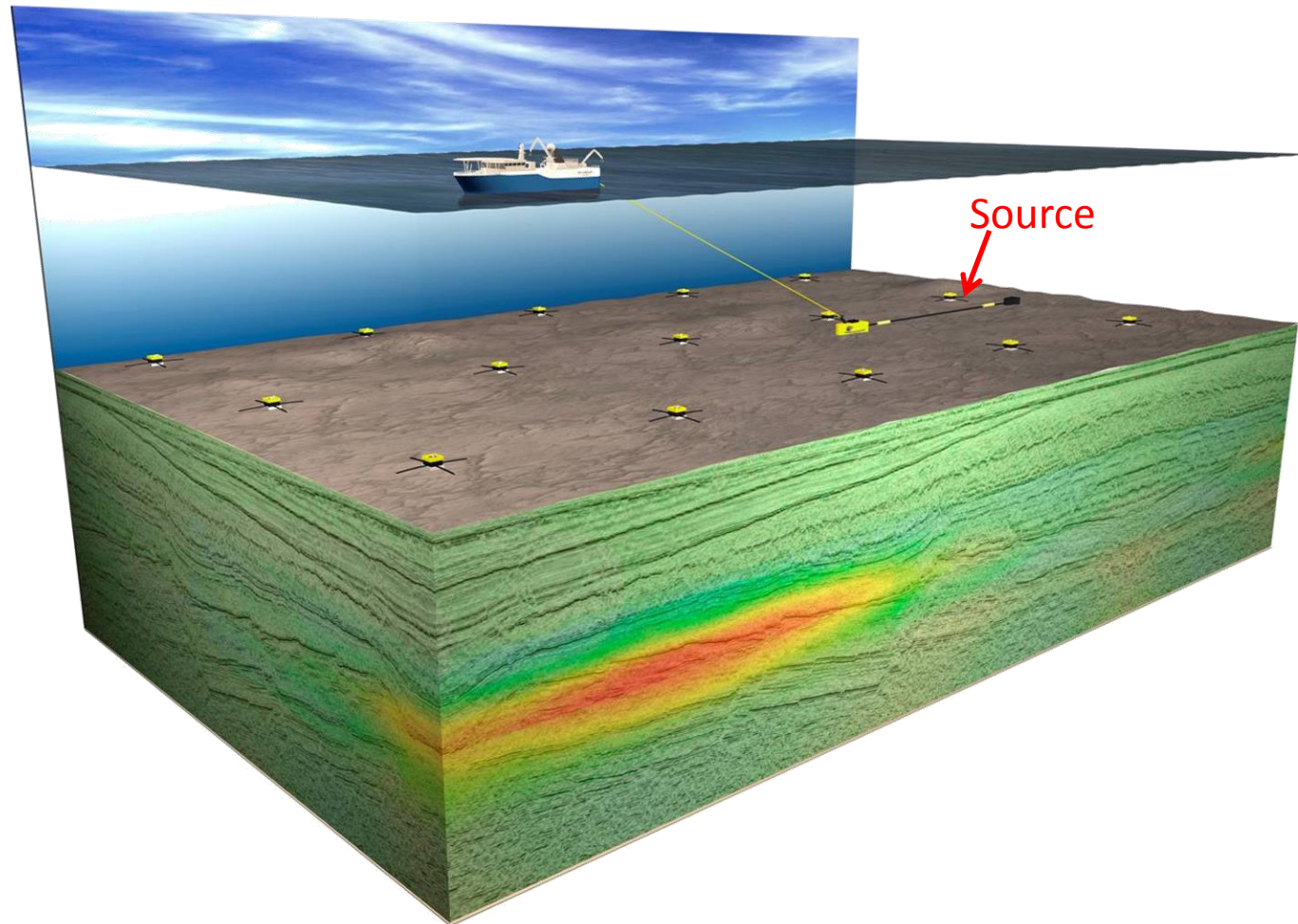

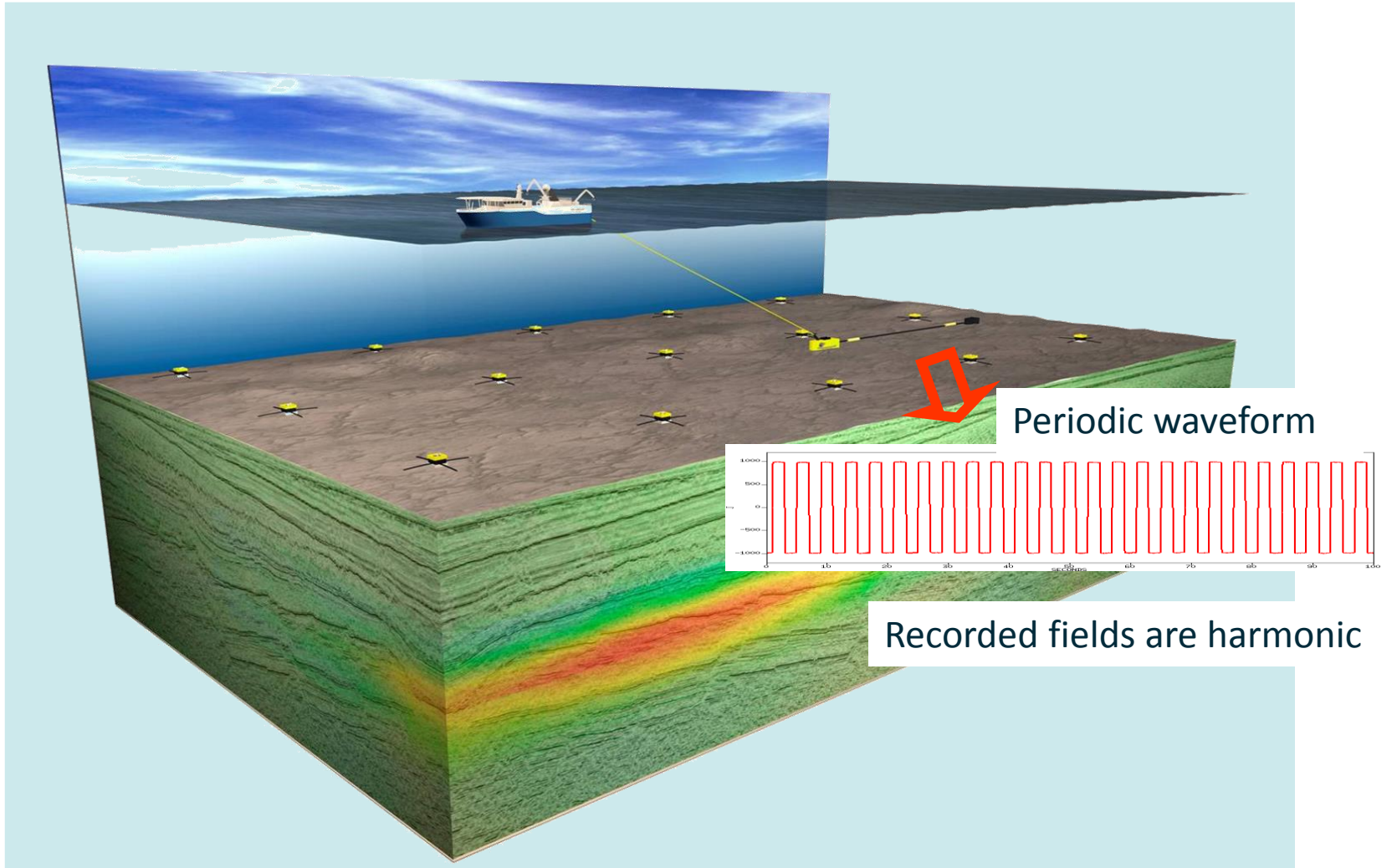

Diffusive fields: «Effective» conversion of electromagnetic energy to heat for typical subsurface resistivities ($\sim 1 \Omega\text{m}$)

Harmonic source:

Repeated signal give stacking effect

Source have high amplitude for 3-5 selected frequencies

Natrural choice to display data in frequency domain

For electric field: $\mathbf{E}(\mathbf{x}, \omega) = \int_0^T dt \mathbf{E}(\mathbf{x}, t) e^{i\omega t}$ (Complex quantity)

Measure horizontal electric and magnetic fields

$$E_x(x, \omega), E_y(x, \omega), H_x(x, \omega), H_y(x, \omega)$$

Complex number can be written as an amplitude times a phase factor.
For example:

$$E_x(x, \omega) = |E_x(x, \omega)|e^{i\phi(x, \omega)}$$

CSEM data is displayed as amplitude and phase versus source-receiver offset

Amplitude (Log scale)

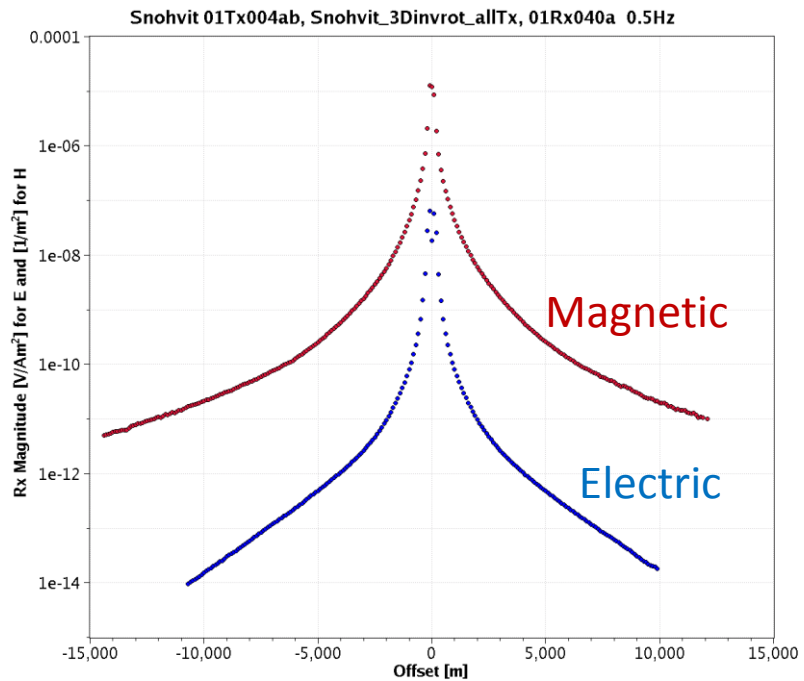

Phase

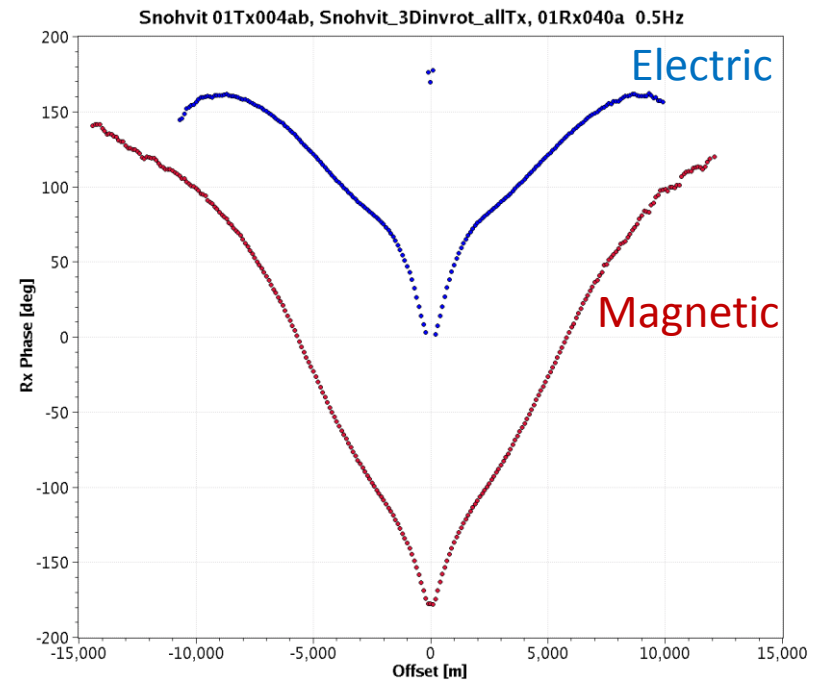

On the electromagnetic fields produced by marine frequency domain controlled sources

A. D. Chave

Forced oscillations of energy in a diffusive medium such as (12) and (13) describe are sometimes called diffusion waves (Mandelis 2006), and it is common in the geophysical literature to refer to CSEM fields using wave equation terminology. However, both (12) and (13) are parabolic diffusion equations rather than hyperbolic wave equations. In one dimension, a parabolic equation has only a single family of characteristic curves (lines of constant t), whereas a hyperbolic equation has two such families (lines of constant $x \pm ct$, where c is the phase velocity). Because they are not invariant under the transformation $t \rightarrow -t$, solutions to parabolic equations evolve unidirectionally forward in time simultaneously at all points away from a source. This set of traits precludes the existence of reflection (and concomitantly, refraction) at interfaces, as well as the use of ray physics. Mandelis *et al.* (2001) summarize the arguments. Consequently, terminology from and analogies to wave phenomena will be avoided in the sequel.

The seismic «interpretation toolbox» is useless!

Or maybe not?

Wave-propagation versus absorption

Notation: $\frac{\partial \psi}{\partial t} \equiv \partial_t \psi$

$$\nabla^2 \psi = \partial_x^2 \psi + \partial_y^2 \psi + \partial_z^2 \psi$$

Fourier transform: $\partial_t \psi \rightarrow -i\omega \psi \quad \omega = 2\pi f$

Wave equation: $\nabla^2 \psi(\mathbf{x}, t) - \frac{1}{c^2(\mathbf{x})} \partial_t^2 \psi(\mathbf{x}, t) = S(\mathbf{x}, t)$

Diffusion equation: $\nabla^2 \psi(\mathbf{x}, t) - \frac{1}{a(\mathbf{x})} \partial_t \psi(\mathbf{x}, t) = S(\mathbf{x}, t)$

Difference wave/diffusion equation is in the order of the time derivative:
Different «physics»

Wave-diffusion correspondence principle

$$\nabla^2 G(\mathbf{x}, t | \mathbf{x}_s) - \frac{1}{c^2(\mathbf{x})} \partial_t^2 G(\mathbf{x}, t | \mathbf{x}_s) = \delta(\mathbf{x} - \mathbf{x}_s) \delta(t)$$

$$\nabla^2 G(\mathbf{x}, \omega' | \mathbf{x}_s) + \frac{\omega'^2}{c^2(\mathbf{x})} G(\mathbf{x}, \omega' | \mathbf{x}_s) = \delta(\mathbf{x} - \mathbf{x}_s)$$

$$\nabla^2 \Gamma(\mathbf{x}, t | \mathbf{x}_s) - \frac{1}{a(\mathbf{x})} \partial_t \Gamma(\mathbf{x}, t | \mathbf{x}_s) = \delta(\mathbf{x} - \mathbf{x}_s) \delta(t)$$

$$\nabla^2 \Gamma(\mathbf{x}, \omega | \mathbf{x}_s) + \frac{i\omega}{a(\mathbf{x})} \Gamma(\mathbf{x}, \omega | \mathbf{x}_s) = \delta(\mathbf{x} - \mathbf{x}_s)$$

Wave-diffusion correspondence principle

$$\nabla^2 G(\mathbf{x}, t | \mathbf{x}_s) - \frac{1}{c^2(\mathbf{x})} \partial_t^2 G(\mathbf{x}, t | \mathbf{x}_s) = \delta(\mathbf{x} - \mathbf{x}_s) \delta(t)$$

$$\nabla^2 G(\mathbf{x}, \omega' | \mathbf{x}_s) + \frac{\omega'^2}{c^2(\mathbf{x})} G(\mathbf{x}, \omega' | \mathbf{x}_s) = \delta(\mathbf{x} - \mathbf{x}_s)$$

$$\nabla^2 \Gamma(\mathbf{x}, t | \mathbf{x}_s) - \frac{1}{a(\mathbf{x})} \partial_t \Gamma(\mathbf{x}, t | \mathbf{x}_s) = \delta(\mathbf{x} - \mathbf{x}_s) \delta(t)$$

$$\nabla^2 \Gamma(\mathbf{x}, \omega | \mathbf{x}_s) + \frac{i\omega}{a(\mathbf{x})} \Gamma(\mathbf{x}, \omega | \mathbf{x}_s) = \delta(\mathbf{x} - \mathbf{x}_s)$$

Reparametrization: $c(\mathbf{x}) = \sqrt{2\omega_0 a(\mathbf{x})} \quad \omega_0 > 0$

Analytical continuation: $\omega' \rightarrow \omega_R + i\omega_I$

Titchmarsh (1948), Theorem 95: $G(\mathbf{x}, t | \mathbf{x}_s) = 0$ for $t \leq 0$

$$\text{Im}(\omega') = \omega_I > 0$$

Particular choice: $\omega' = \sqrt{2i\omega_0\omega} = (1+i)\sqrt{\omega_0\omega}$

Wave-diffusion correspondence principle

$$\nabla^2 G(\mathbf{x}, t | \mathbf{x}_s) - \frac{1}{c^2(\mathbf{x})} \partial_t^2 G(\mathbf{x}, t | \mathbf{x}_s) = \delta(\mathbf{x} - \mathbf{x}_s) \delta(t)$$

$$\nabla^2 \Gamma(\mathbf{x}, t | \mathbf{x}_s) - \frac{1}{a(\mathbf{x})} \partial_t \Gamma(\mathbf{x}, t | \mathbf{x}_s) = \delta(\mathbf{x} - \mathbf{x}_s) \delta(t)$$

$$\nabla^2 G(\mathbf{x}, \omega' | \mathbf{x}_s) + \frac{\omega'^2}{c^2(\mathbf{x})} G(\mathbf{x}, \omega' | \mathbf{x}_s) = \delta(\mathbf{x} - \mathbf{x}_s)$$

$$\nabla^2 \Gamma(\mathbf{x}, \omega | \mathbf{x}_s) + \frac{i\omega}{a(\mathbf{x})} \Gamma(\mathbf{x}, \omega | \mathbf{x}_s) = \delta(\mathbf{x} - \mathbf{x}_s)$$

$$c(\mathbf{x}) = \sqrt{2\omega_0 a(\mathbf{x})} \quad \omega' = \sqrt{2i\omega_0 \omega}$$

$$\nabla^2 G(\mathbf{x}, \omega' | \mathbf{x}_s) + \frac{i\omega}{a(\mathbf{x})} G(\mathbf{x}, \omega' | \mathbf{x}_s) = \delta(\mathbf{x} - \mathbf{x}_s)$$

$$G(\mathbf{x}, \omega' | \mathbf{x}_s) = \int_0^T dt' G(\mathbf{x}, t' | \mathbf{x}_s) e^{i\omega' t'} \quad \omega' = (1+i)\sqrt{\omega_0 \omega}$$

$$G(\mathbf{x}, \omega | \mathbf{x}_s) = \int_0^T dt' G(\mathbf{x}, t' | \mathbf{x}_s) e^{-\sqrt{\omega_0 \omega} t'} e^{i\sqrt{\omega_0 \omega} t'}$$

The «Grad Div» operator

The following operator occurs for the electromagnetic wave and diffusion equations: $\nabla(\nabla \cdot \mathbf{E})$

The result is a vector: $\mathbf{F} = \nabla(\nabla \cdot \mathbf{E})$

Gauss's law in vacuum: $\nabla \cdot \mathbf{E} = \frac{q}{\varepsilon_0}$

$$\begin{bmatrix} F_x \\ F_y \\ F_z \end{bmatrix} = \frac{1}{\varepsilon_0} \begin{bmatrix} \partial_x q \\ \partial_y q \\ \partial_z q \end{bmatrix}$$

Note: $\nabla \cdot \mathbf{E} = 0$ if the charge density is zero.

$$\rho \partial_t \mathbf{v} = -\nabla P + \mathbf{f}^{Source}$$

Newton's second law

$$\partial_t P = -M \nabla \cdot \mathbf{v}$$

Hooke's law for acoustic medium

Pressure: P

Particle velocity: \mathbf{v}

Density: ρ

Bulk modulus: M

Source force density: \mathbf{f}^{Source}

These two equations can be combined and give a wave equation.

Assuming constant density:

$$\nabla^2 P(\mathbf{x}, t) - \frac{1}{\frac{M(\mathbf{x})}{\rho_0}} \partial_t^2 P(\mathbf{x}, t) = \nabla \cdot \mathbf{f}^{Source}(\mathbf{x}, t)$$

$$\epsilon_r \epsilon_0 \partial_t \mathbf{E} + \sigma \mathbf{E} = \nabla \times \mathbf{H} - \mathbf{J}^{source} \quad (\text{Ampere's law})$$

$$\mu_0 \partial_t \mathbf{H} = -\nabla \times \mathbf{E} \quad (\text{Faraday's law})$$

Electric field: \mathbf{E}

Magnetic field: \mathbf{H}

Conductivity: σ

Resistivity: $\rho = 1/\sigma$

Electric permittivity of vacuum: $\epsilon_0 = 8.85 \times 10^{-12}$ F/m

Relative electric permittivity: ϵ_r

Magnetic permeability of vacuum: $\mu_0 = 4\pi \times 10^{-7}$ H/m

Source current density: \mathbf{J}^{source}

These two equations can be combined and give the equation:

$$\nabla^2 \mathbf{E}(\mathbf{x}, t) - \nabla(\nabla \cdot \mathbf{E}(\mathbf{x}, t)) - \mu_0 \epsilon_r(\mathbf{x}) \epsilon_0 \partial_t^2 \mathbf{E}(\mathbf{x}, t) - \mu_0 \sigma(\mathbf{x}) \partial_t \mathbf{E}(\mathbf{x}, t) = \mu_0 \partial_t \mathbf{J}^{source}(\mathbf{x}, t)$$

In vacuum:
$$\nabla^2 \mathbf{E}(\mathbf{x}, t) - \mu_0 \epsilon_0 \partial_t^2 \mathbf{E}(\mathbf{x}, t) = \mu_0 \partial_t \mathbf{J}^{source}(\mathbf{x}, t)$$

$$\nabla^2 \mathbf{E}(\mathbf{x}, t) - \nabla(\nabla \cdot \mathbf{E}(\mathbf{x}, t)) - \underbrace{\mu_0 \epsilon_r(\mathbf{x}) \epsilon_0}_{\mu_0 \epsilon_r(\mathbf{x}) \epsilon_0 \omega^2} \partial_t^2 \mathbf{E}(\mathbf{x}, t) - \underbrace{\mu_0 \sigma(\mathbf{x})}_{i\mu_0 \sigma(\mathbf{x}) \omega} \partial_t \mathbf{E}(\mathbf{x}, t) = \mu_0 \partial_t \mathbf{J}^{Source}(\mathbf{x}, t)$$

Note: $\epsilon_r = 80$ for seawater

For seawater:

f [Hz]	$\omega \epsilon_r \epsilon_0$ [S/m]	σ [S/m]	
1	4.4×10^{-9}	3.2	CSEM - Diffusive
10^9	4.4	3.2	GPR - Mixed
5×10^{14}	2.2×10^6	3.2	Visible light - Wave

Safe to neglect second derivative term for CSEM and MT frequency band

$$\nabla^2 \mathbf{E}(\mathbf{x}, t) - \nabla(\nabla \cdot \mathbf{E}(\mathbf{x}, t)) - \mu_0 \varepsilon_r(\mathbf{x}) \varepsilon_0 \partial_t^2 \mathbf{E}(\mathbf{x}, t) - \mu_0 \sigma(\mathbf{x}) \partial_t \mathbf{E}(\mathbf{x}, t) = \mu_0 \partial_t \mathbf{J}^{Source}(\mathbf{x}, t)$$

The quasi-static approximation: Neglect displacement currents
Diffusive field equation for low frequency geophysical problems

$$\nabla^2 \mathbf{E}(\mathbf{x}, t) - \nabla(\nabla \cdot \mathbf{E}(\mathbf{x}, t)) - \mu_0 \sigma(\mathbf{x}) \partial_t \mathbf{E}(\mathbf{x}, t) = \mu_0 \partial_t \mathbf{J}^{Source}(\mathbf{x}, t)$$

Typical for diffusive systems:

- I) Very strong absorption – loss of amplitude with propagation
(here the effect is transformation of electromagnetic energy to heat. Resistive heating and induction heating)
- II) Dispersion – different frequencies propagate with different velocity

Transform methods in modeling

Frequency domain CSEM data can be simulated by several methods:

Simulate the diffusive Maxwell equations in the space-time domain and Fourier transform the simulated data to the frequency domain.

Fourier transform the diffusive Maxwell equations to the frequency domain and do the simulation in space-frequency domain.

However, diffusive equations have an interesting property:

- The wave equation can give the solution for a corresponding diffusive equation.
- The wave fields so simulated can be transformed to the (diffusive) frequency domain by a transform kernel that is similar to a complex Laplace transform.
- Known as the correspondence principle for time-domain electromagnetic wave and diffusion fields but valid for other systems

A general correspondence principle for time-domain electromagnetic wave and diffusion fields

Adrianus T. de Hoop*

Schlumberger-Doll Research, Old Quarry Road, Ridgefield CT 06877-4108, USA

Accepted 1996 August 28. Received 1996 August 21; in original form 1995 October 10

To obtain the time-domain expressions for each Γ , the Schouten–Van der Pol theorem in the theory of Laplace transformation is applied. This theorem relates time-domain results that are associated with the replacement of the Laplace-transform parameter s by a function of s , subject to some restrictions. For the present case, the result for the replacement of s by $(\alpha s)^{1/2}$ is needed. Using eqs (A6), (A9) and (A10) from Appendix A, it is found that

$$\Gamma^{E,H|J,K}(\mathbf{r}, \mathbf{r}', t) = \left[\int_{\tau=0}^{\infty} W^{E,H|J,K}(t, \tau, \alpha) \mathcal{G}^{E,H|J,K}(\mathbf{r}, \mathbf{r}', \tau) d\tau \right] H(t), \quad (24)$$

where the intervening kernel functions $W^{E,H|J,K}$ are given by

$$W^{E,J} = \frac{1}{2} \left(\frac{1}{\alpha\pi} \right)^{1/2} \frac{1}{t^{3/2}} \left(\frac{\alpha\tau^2}{2t} - 1 \right) \exp\left(-\frac{\alpha\tau^2}{4t} \right) H(t), \quad (25)$$

$$W^{H,J} = \frac{1}{2} \left(\frac{\alpha}{\pi} \right)^{1/2} \frac{\tau}{t^{3/2}} \exp\left(-\frac{\alpha\tau^2}{4t} \right) H(t), \quad (26)$$

$$W^{E,K} = \frac{1}{2} \left(\frac{\alpha}{\pi} \right)^{1/2} \frac{\tau}{t^{3/2}} \exp\left(-\frac{\alpha\tau^2}{4t} \right) H(t), \quad (27)$$

$$W^{H,K} = \left(\frac{\alpha}{\pi t} \right)^{1/2} \exp\left(-\frac{\alpha\tau^2}{4t} \right) H(t), \quad (28)$$

Transform from fictitious time solution in the wave domain to real time solution in the diffusive domain.

Simulation of diffusive Maxwell equation in the time domain

$$\nabla^2 \mathbf{E}(\mathbf{x}, t) - \nabla(\nabla \cdot \mathbf{E}(\mathbf{x}, t)) - \mu_0 \sigma(\mathbf{x}) \partial_t \mathbf{E}(\mathbf{x}, t) = \mu_0 \partial_t \mathbf{J}^{Source}(\mathbf{x}, t)$$

Frequency domain response by Fourier transform

$$\mathbf{E}(\mathbf{x}, \omega) = \int_0^T dt \mathbf{E}(\mathbf{x}, t) e^{i\omega t}$$

Solving diffusive Maxwell equation in the frequency domain

$$\nabla^2 \mathbf{E}(\mathbf{x}, \omega) - \nabla(\nabla \cdot \mathbf{E}(\mathbf{x}, \omega)) + i\omega \mu_0 \sigma(\mathbf{x}) \mathbf{E}(\mathbf{x}, \omega) = -i\omega \mu_0 \mathbf{J}^{Source}(\mathbf{x}, \omega)$$

Transform Maxwell equation

$$\nabla^2 \mathbf{E}(\mathbf{x}, t) - \nabla(\nabla \cdot \mathbf{E}(\mathbf{x}, t)) - \mu_0 \sigma(\mathbf{x}) \partial_t \mathbf{E}(\mathbf{x}, t) = \mu_0 \partial_t \mathbf{J}^{Source}(\mathbf{x}, t)$$



Between first and second order in time

$$\nabla^2 \mathbf{E}'(\mathbf{x}, t') - \nabla(\nabla \cdot \mathbf{E}'(\mathbf{x}, t')) - \frac{\mu_0 \sigma(\mathbf{x})}{2\omega_0} \partial_{t'}^2 \mathbf{E}'(\mathbf{x}, t') = \frac{\mu_0}{2\omega_0} \partial_{t'}^2 \mathbf{J}^{Source}(\mathbf{x}, t')$$

Diffusive frequency domain response by transform:

$$\mathbf{E}(\mathbf{x}, \omega) = \int_0^T dt' \mathbf{E}'(\mathbf{x}, t') e^{-\sqrt{\omega\omega_0}t'} e^{i\sqrt{\omega\omega_0}t'}$$

$$\mathbf{E}(\mathbf{x}, \omega) = \int_0^T dt \mathbf{E}(\mathbf{x}, t) e^{i\omega t}$$

The scale parameter ω_0 must be larger than zero.

Note: Exponential damping with time

High frequencies more damped than low frequencies

The acoustic wave equation

$$\nabla^2 P(\mathbf{x}, t) - \frac{1}{c^2(\mathbf{x})} \partial_t^2 P(\mathbf{x}, t) = \nabla \cdot \mathbf{f}^{Source}(\mathbf{x}, t)$$

Acoustic velocity

$$c(\mathbf{x}) = \sqrt{\frac{M(\mathbf{x})}{\rho_0}}$$

The electromagnetic wave equation

$$\nabla^2 \mathbf{E}'(\mathbf{x}, t') - \nabla(\nabla \cdot \mathbf{E}'(\mathbf{x}, t')) - \frac{1}{c^2(\mathbf{x})} \partial_{t'}^2 \mathbf{E}'(\mathbf{x}, t') = \mu_0 \partial_{t'} \mathbf{J}^{Source}(\mathbf{x}, t')$$

Electromagnetic velocity

$$c(\mathbf{x}) = \sqrt{\frac{2\omega_0}{\mu_0 \sigma(\mathbf{x})}}$$

3D acoustic simulation

Waterdepth 2 km

«High velocity» subsurface (2 – 6 km)

Source 40 m above seabed (1.96 km)

Recording at seabed (2 km)

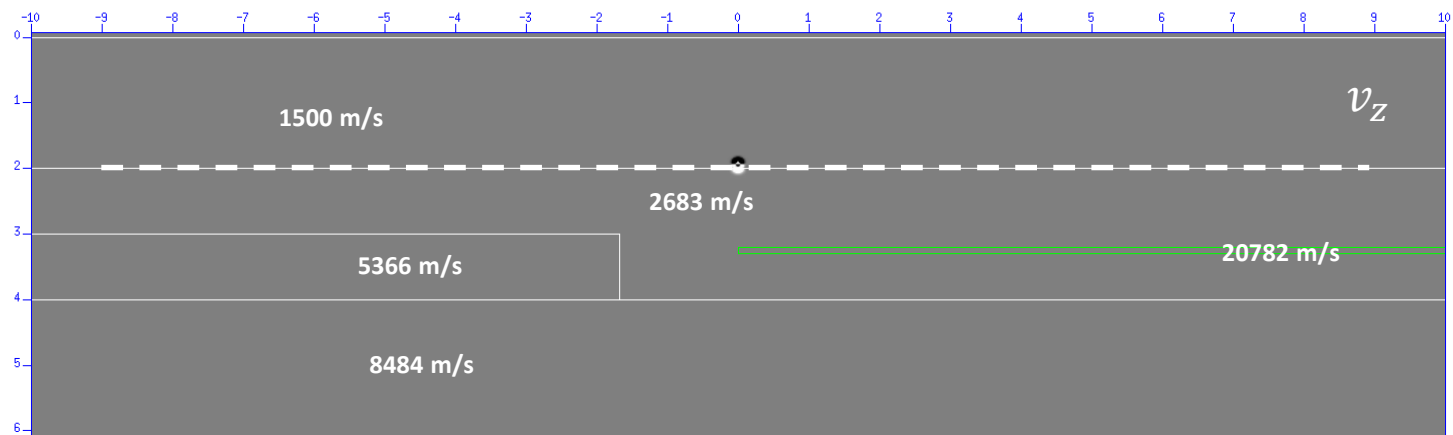

Vertical component of particle velocity

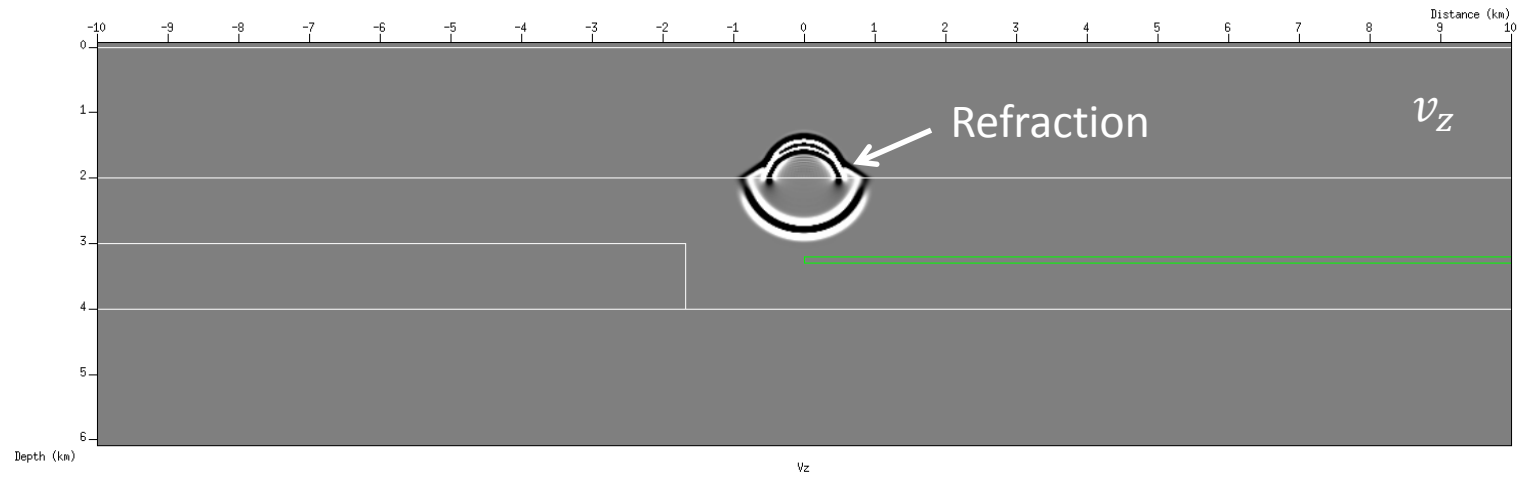

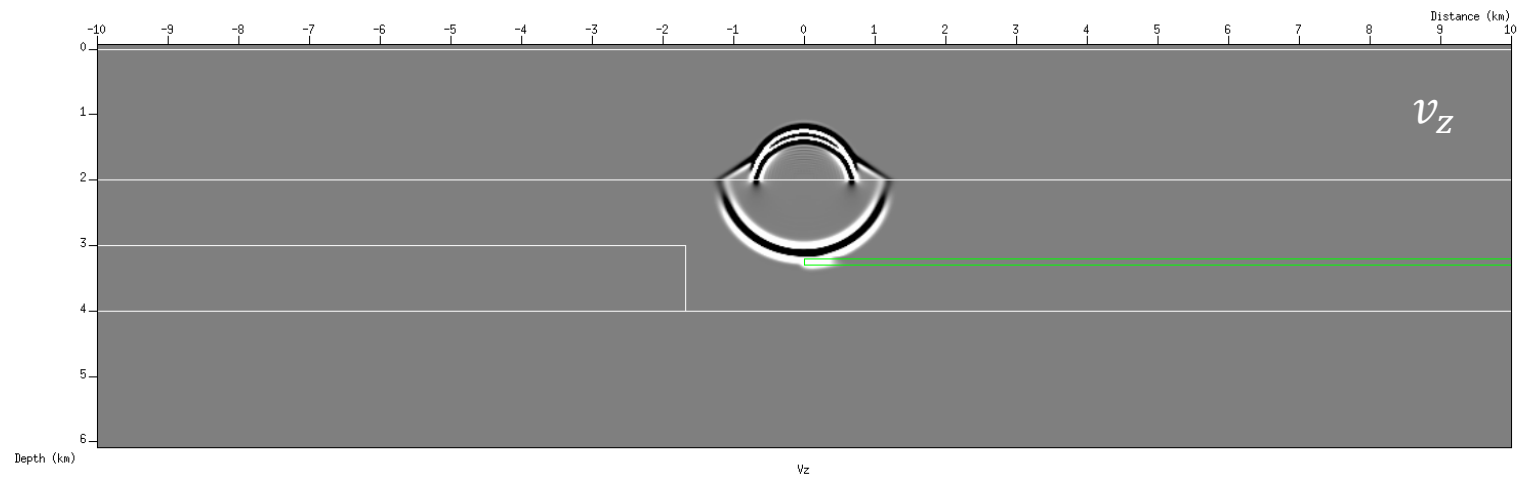

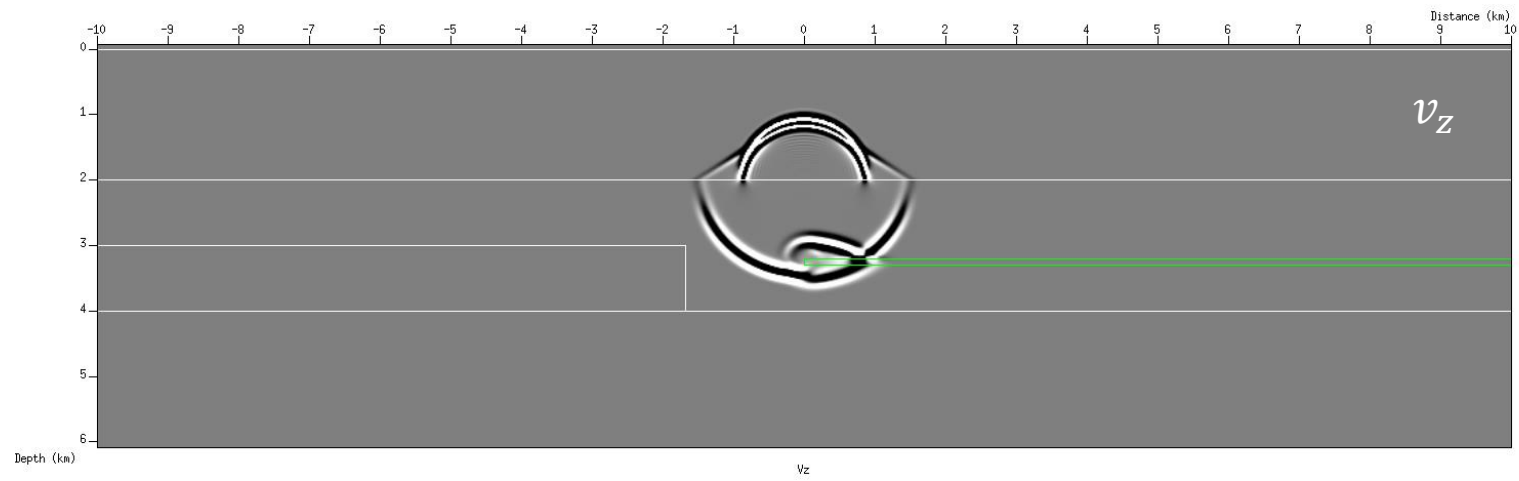

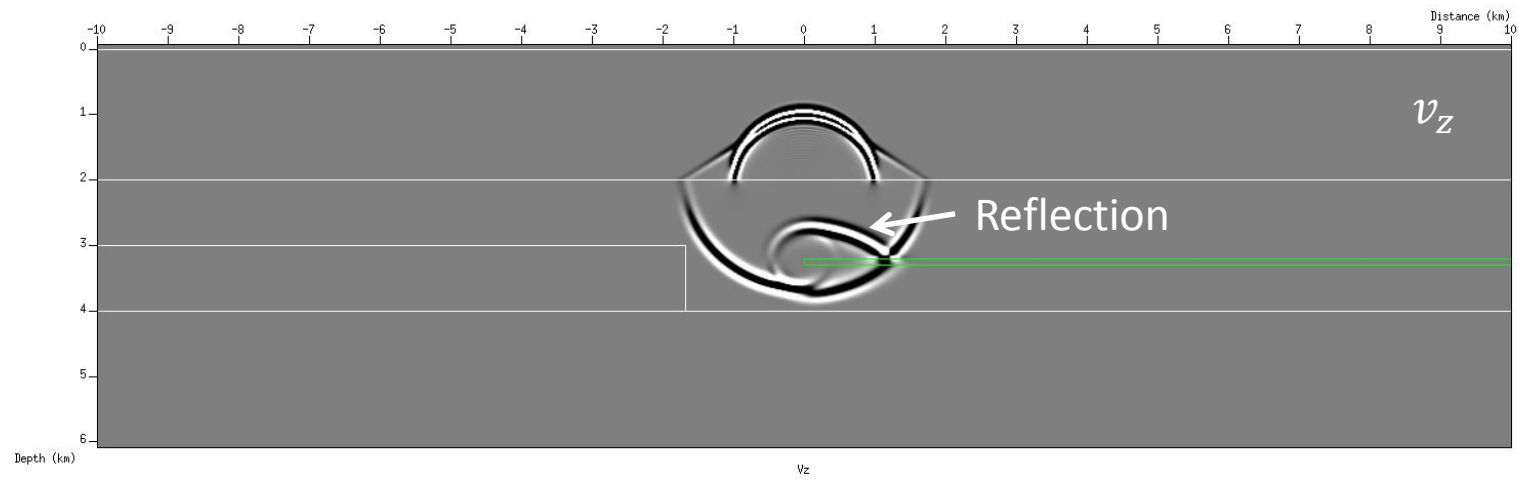

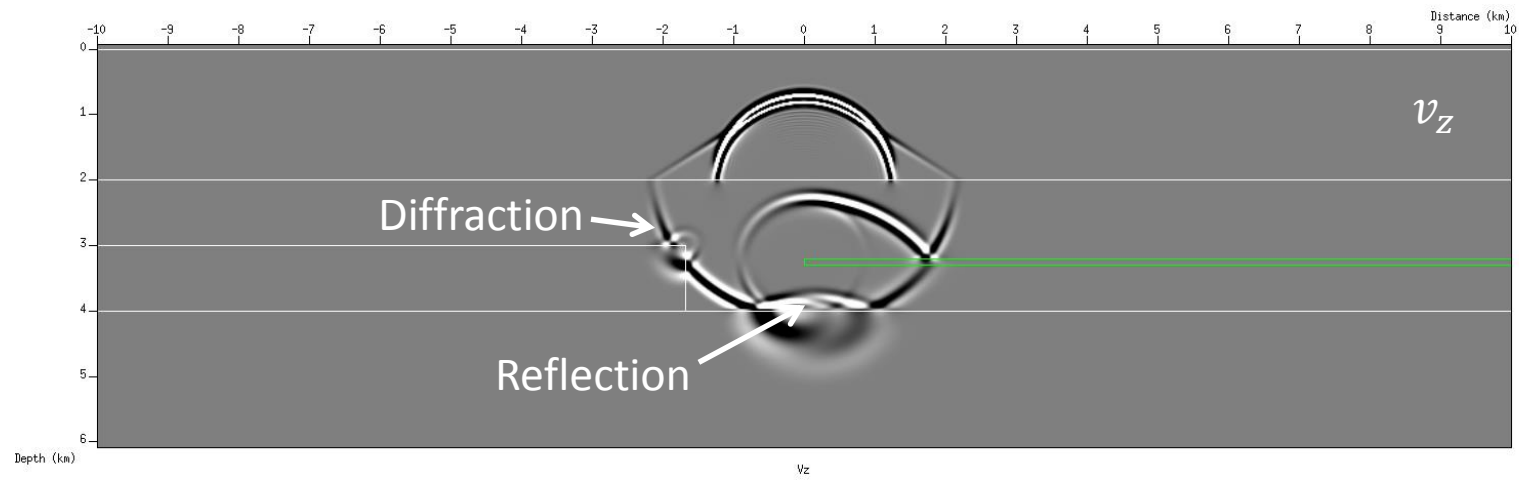

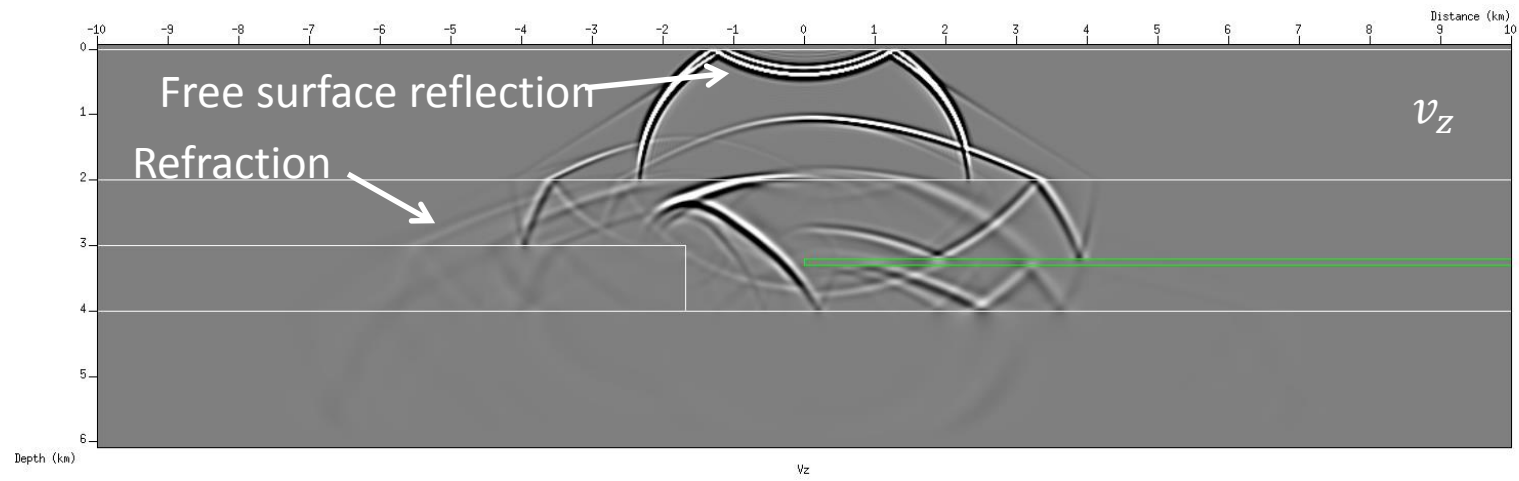

Air-water reflection at seabed after ~ 2.7 s (4000 m / 1500 m/s)

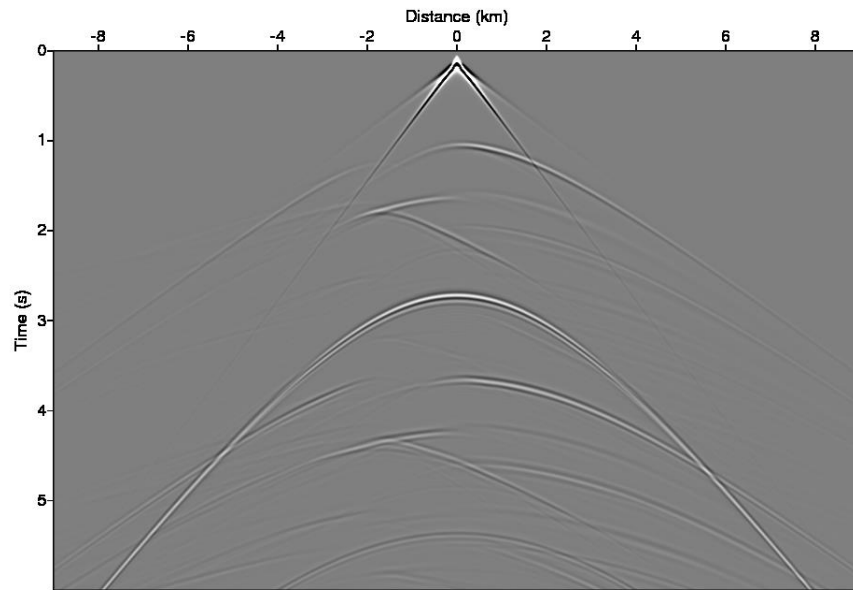

Traces normalized to unity

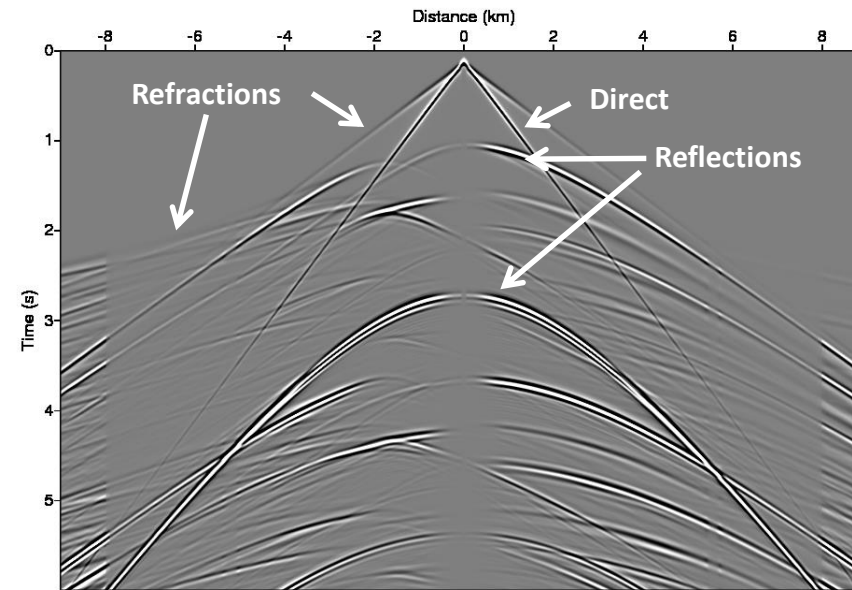

Also diffractions and multiples

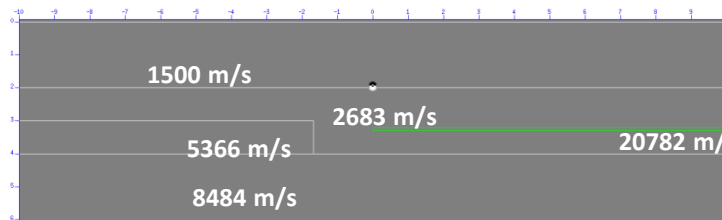

3D acoustic simulation and 3D EM simulation

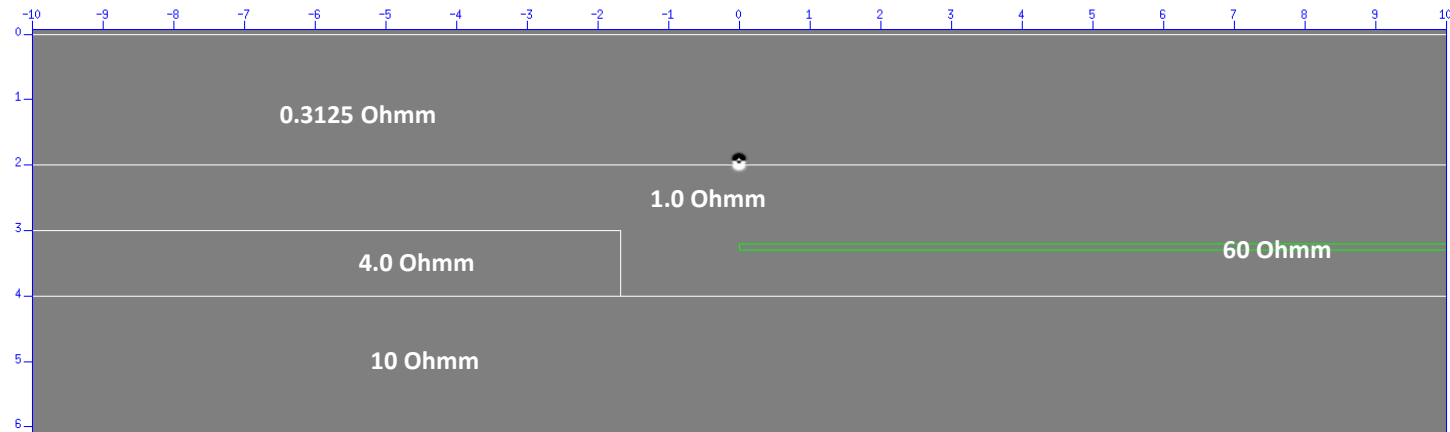
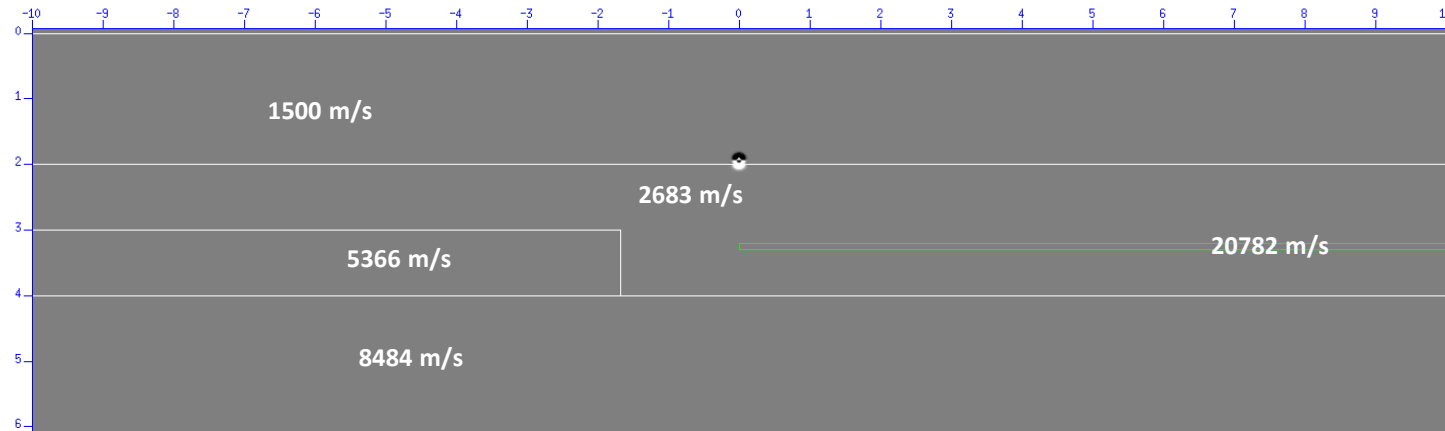

3D acoustic simulation and 3D EM simulation

$$\sigma(\mathbf{x}) = \frac{1}{\rho(\mathbf{x})} \quad c(\mathbf{x}) = \sqrt{\frac{2\omega_0}{\mu\sigma(\mathbf{x})}} \quad \omega_0 = 2\pi f_0 \quad f_0 = 0.7198 \text{ Hz}$$

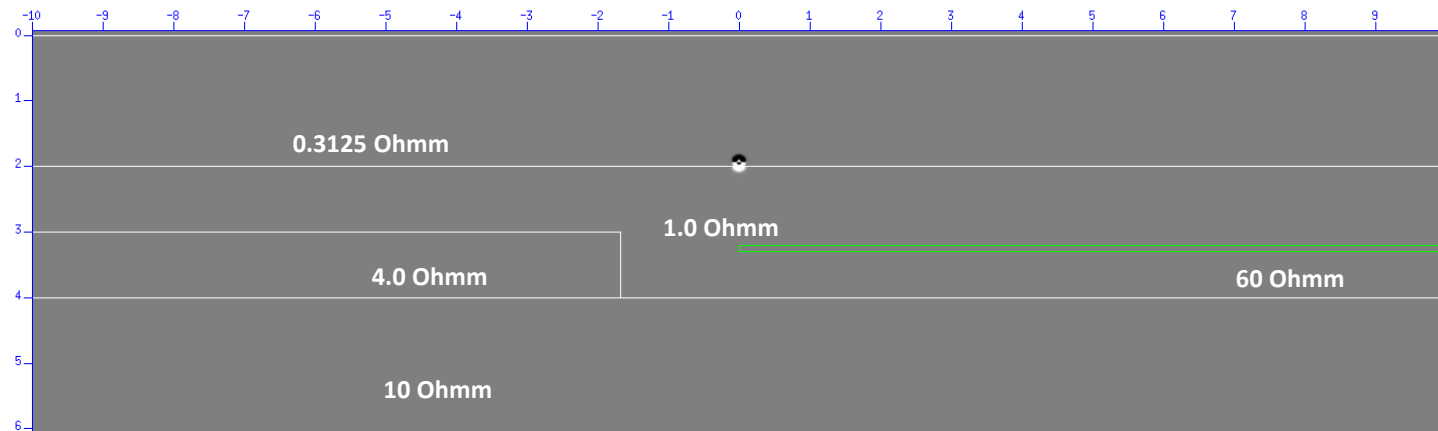
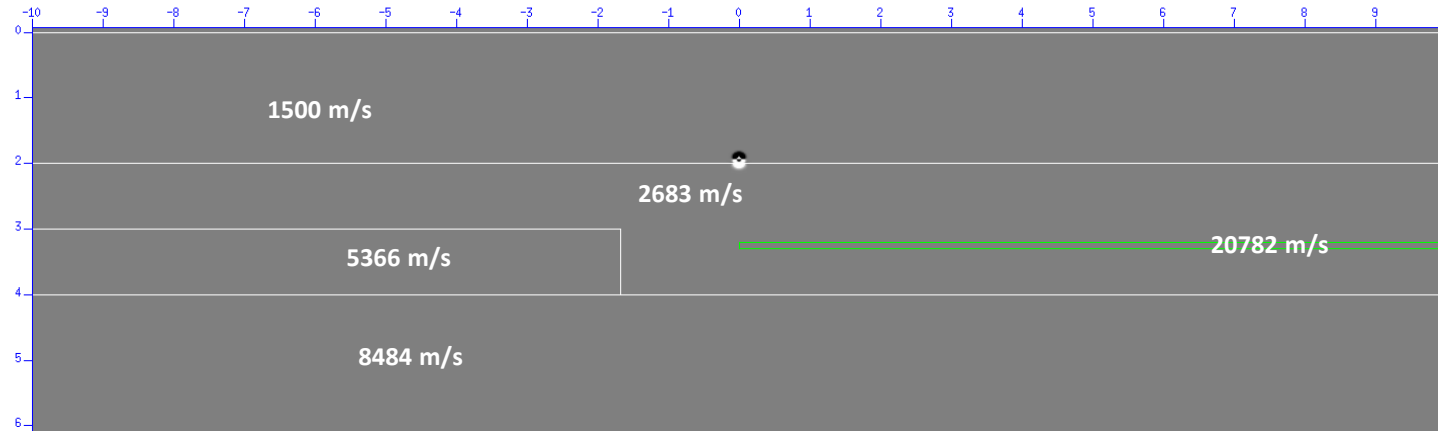

Resistivity/conductivity model maps into velocity model

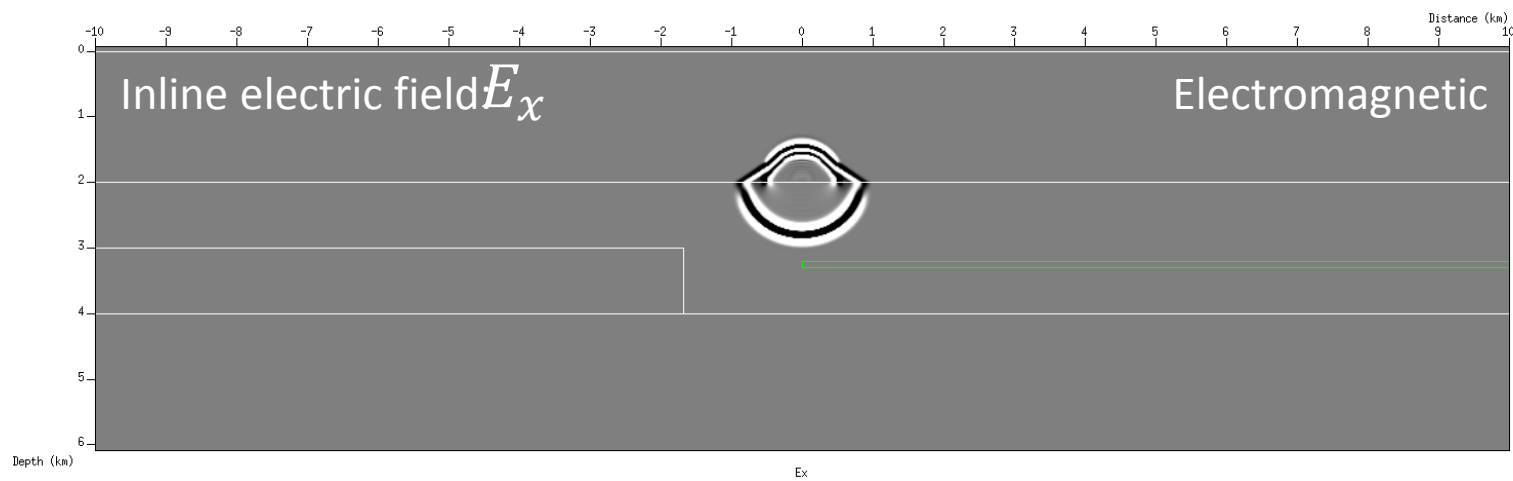
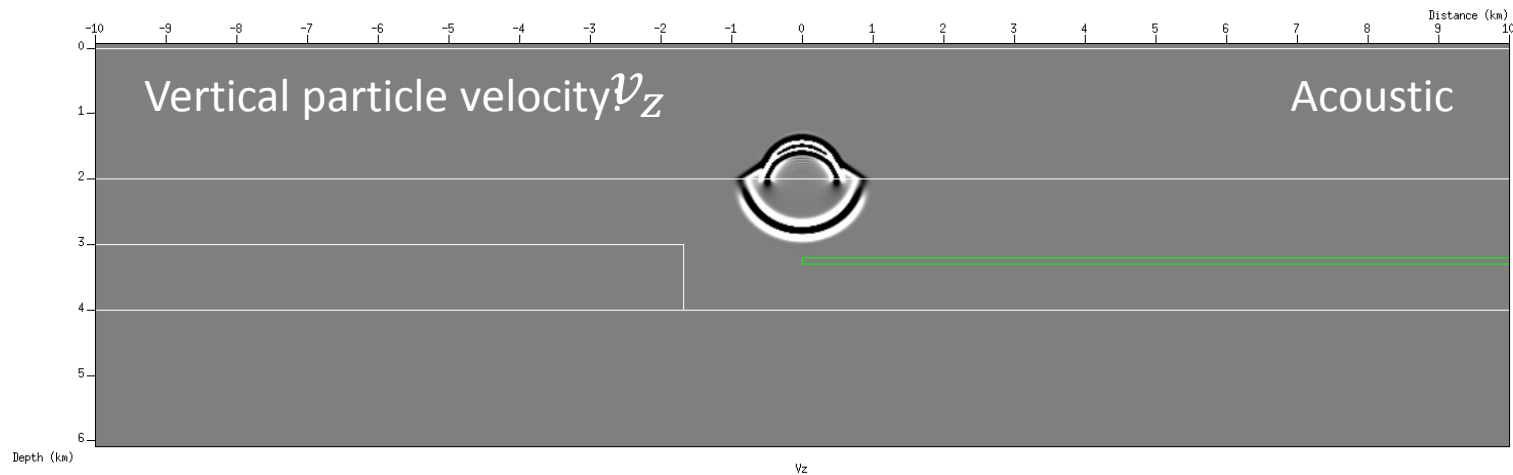

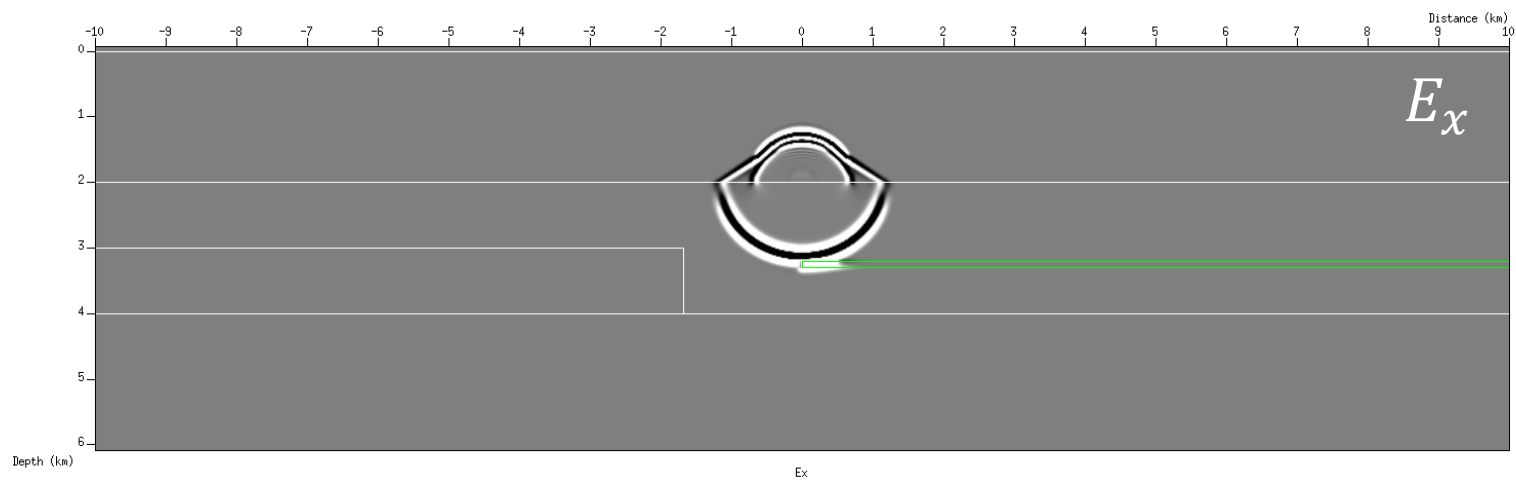
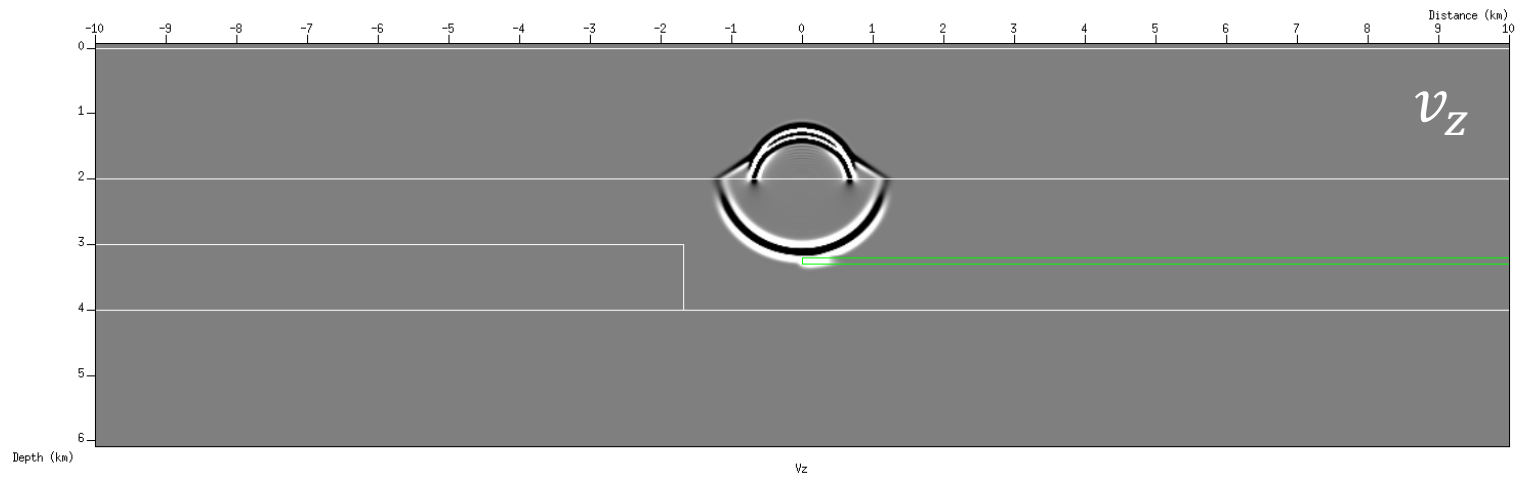

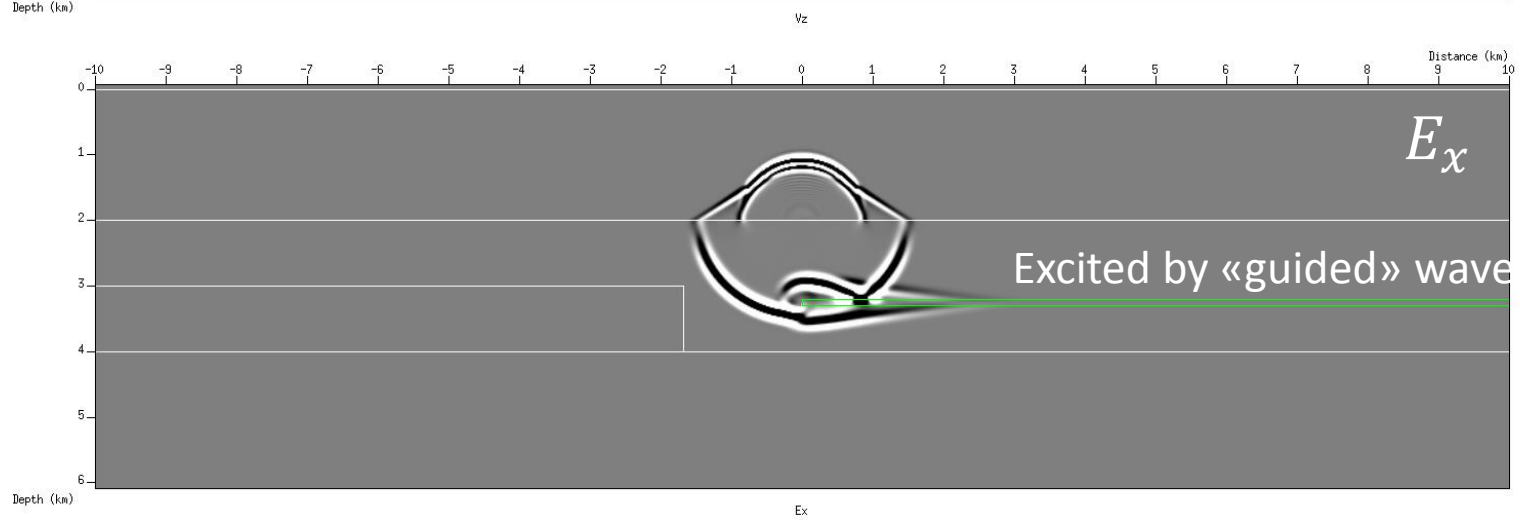
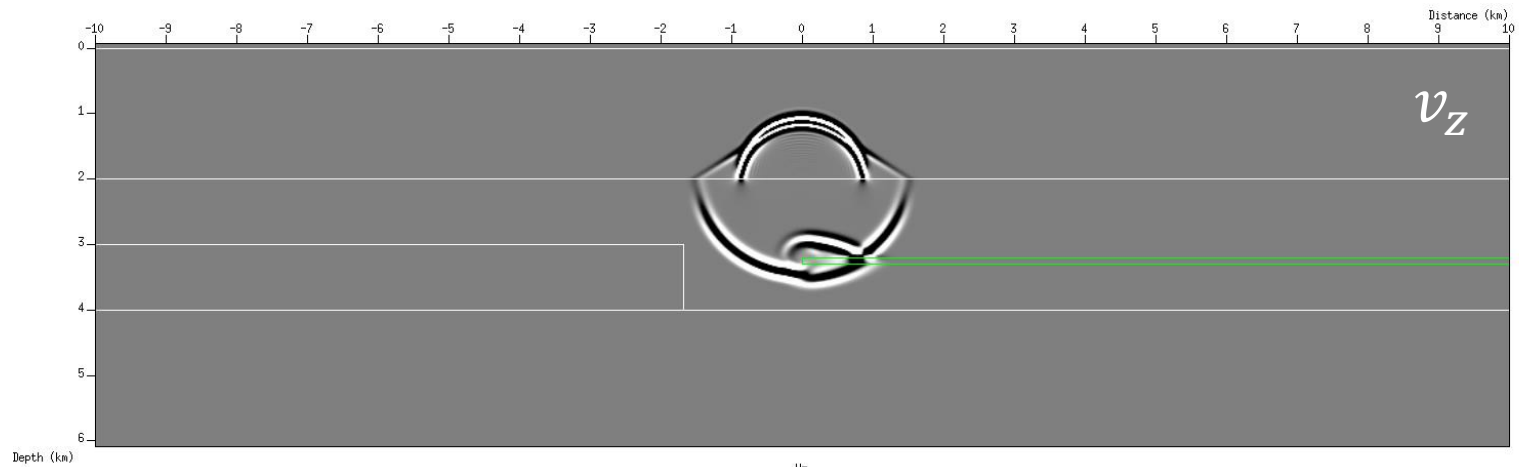

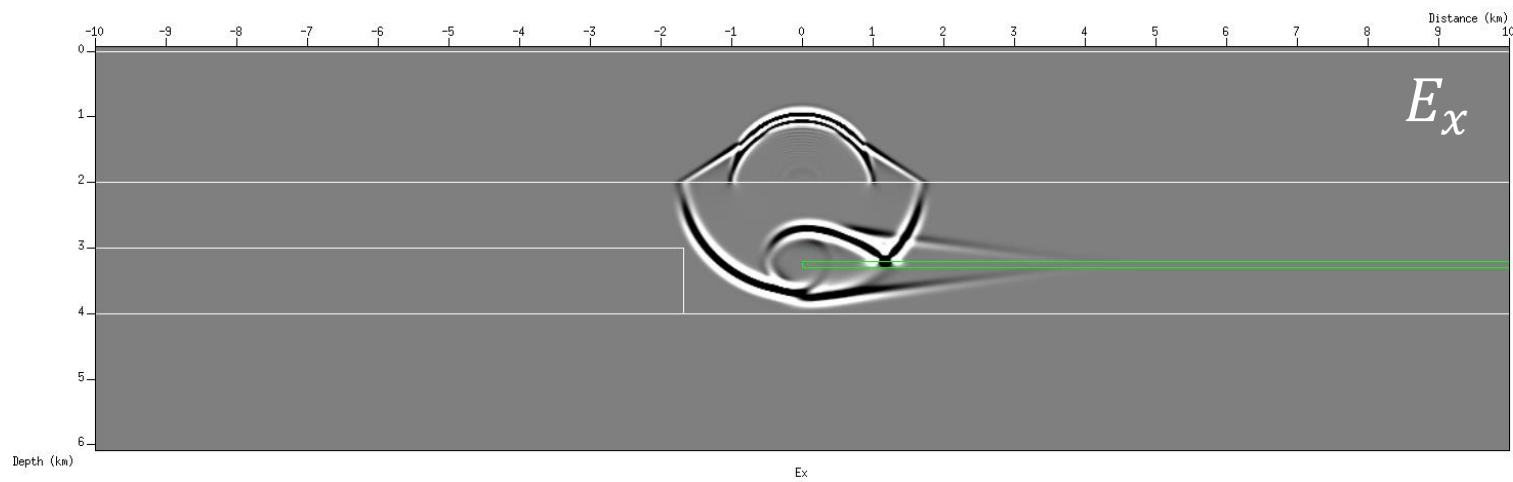
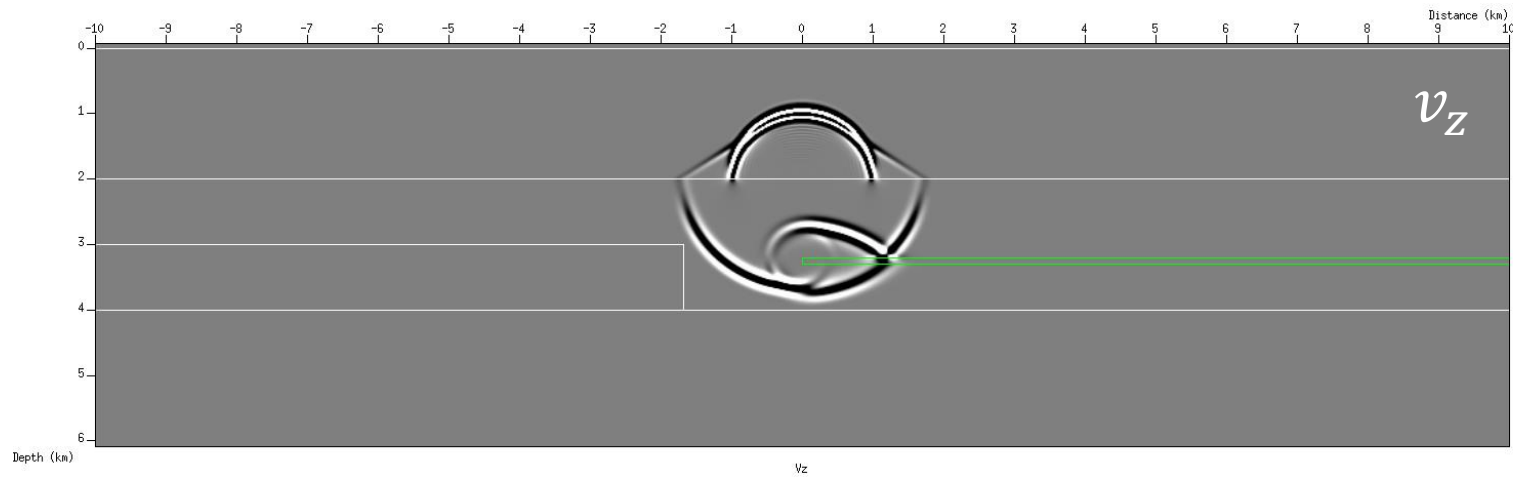

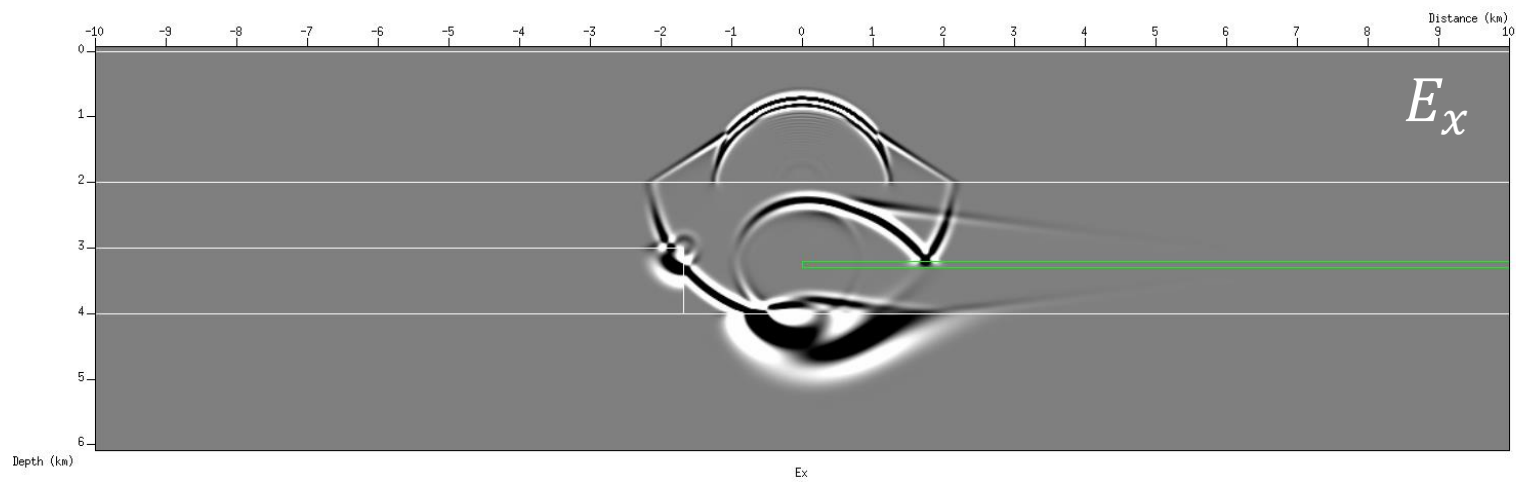
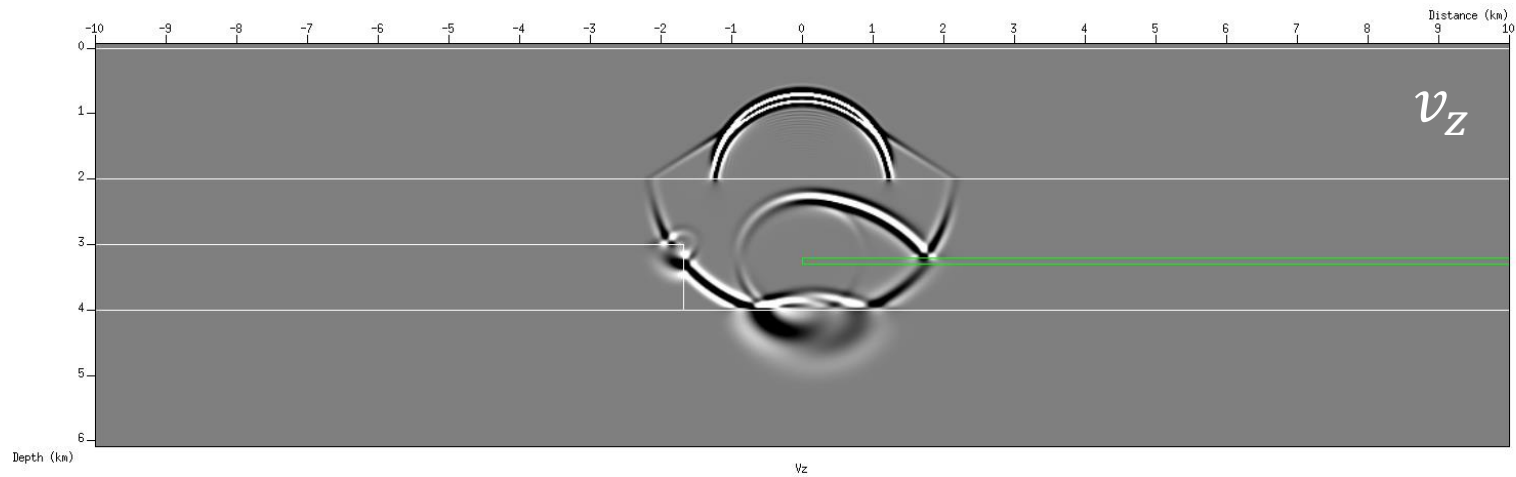

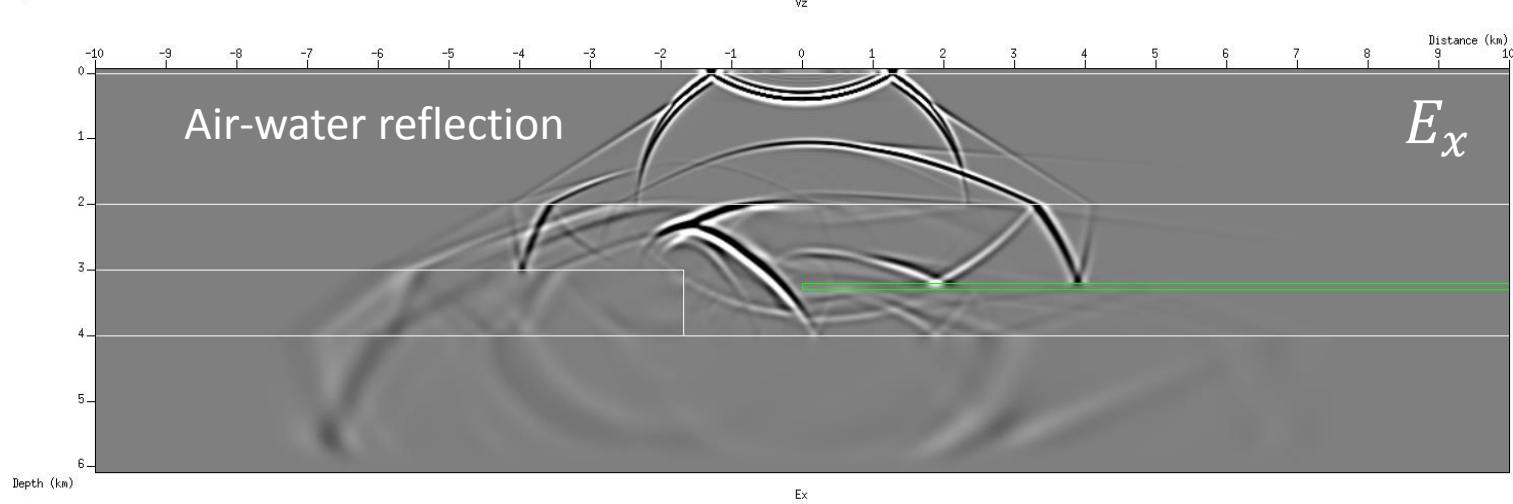
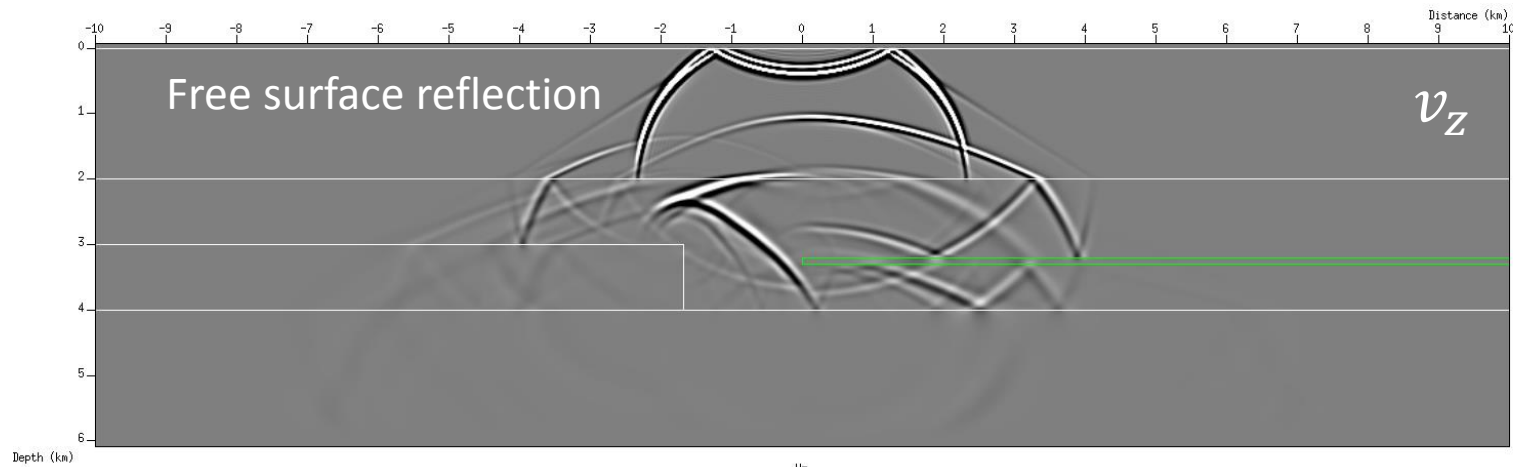

Acoustic

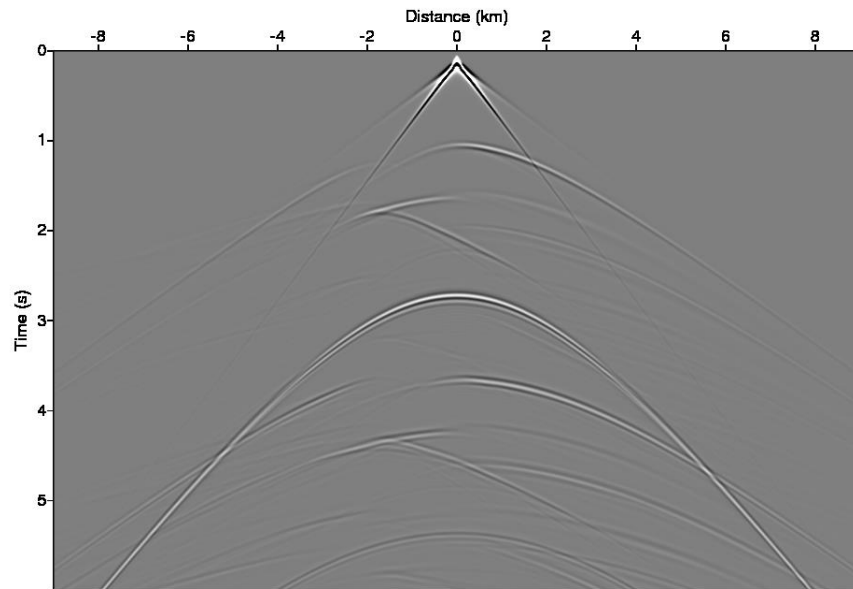

Electromagnetic

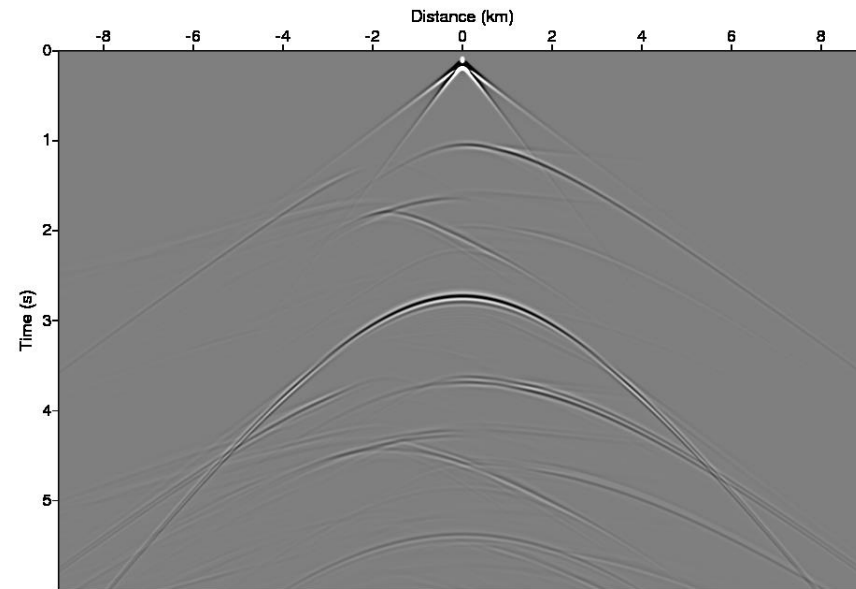

Traces normalized to unity

Acoustic

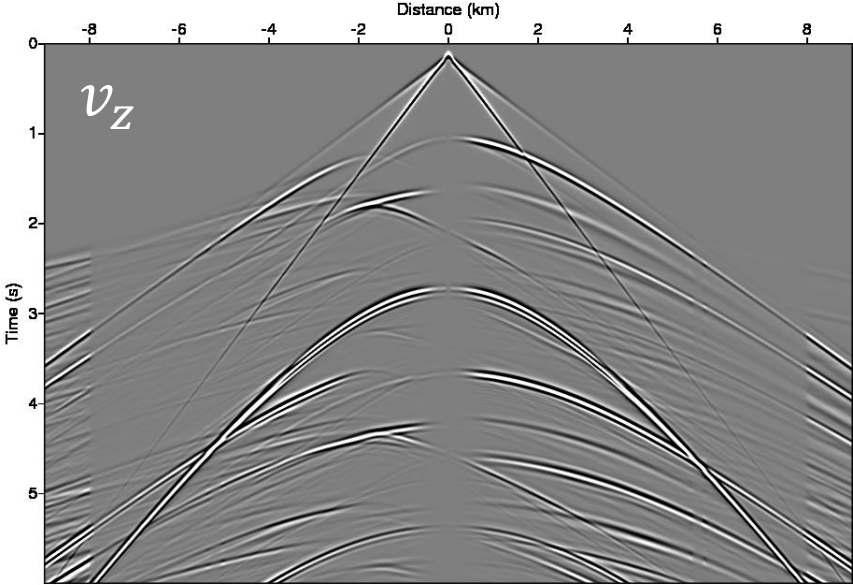

Electromagnetic

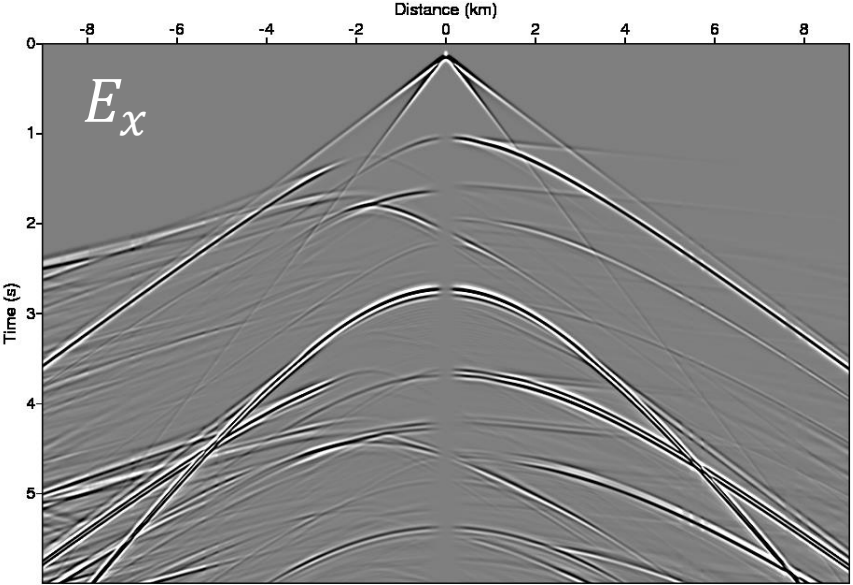

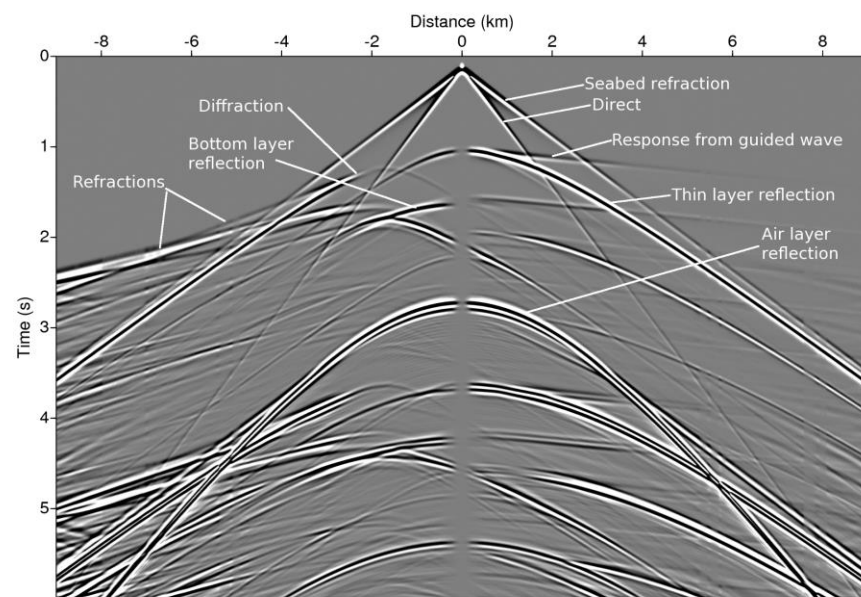
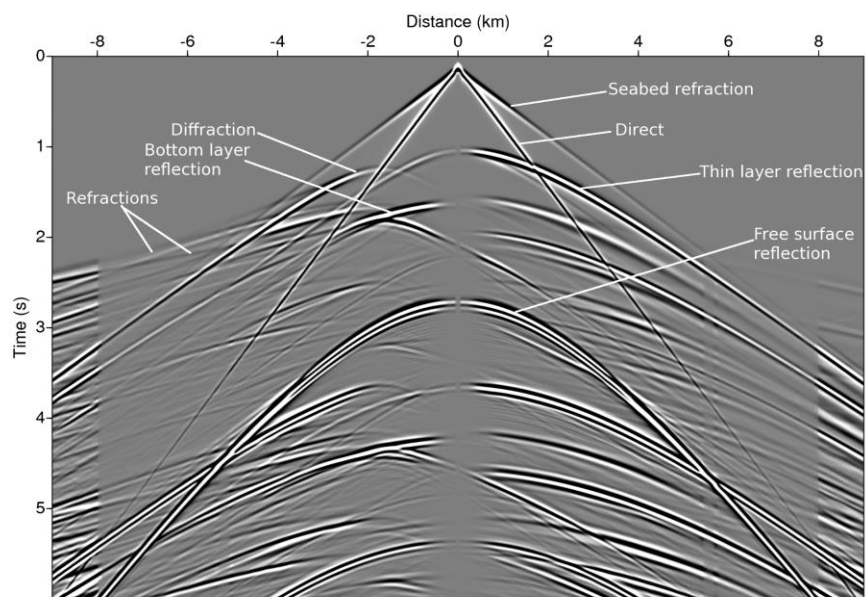

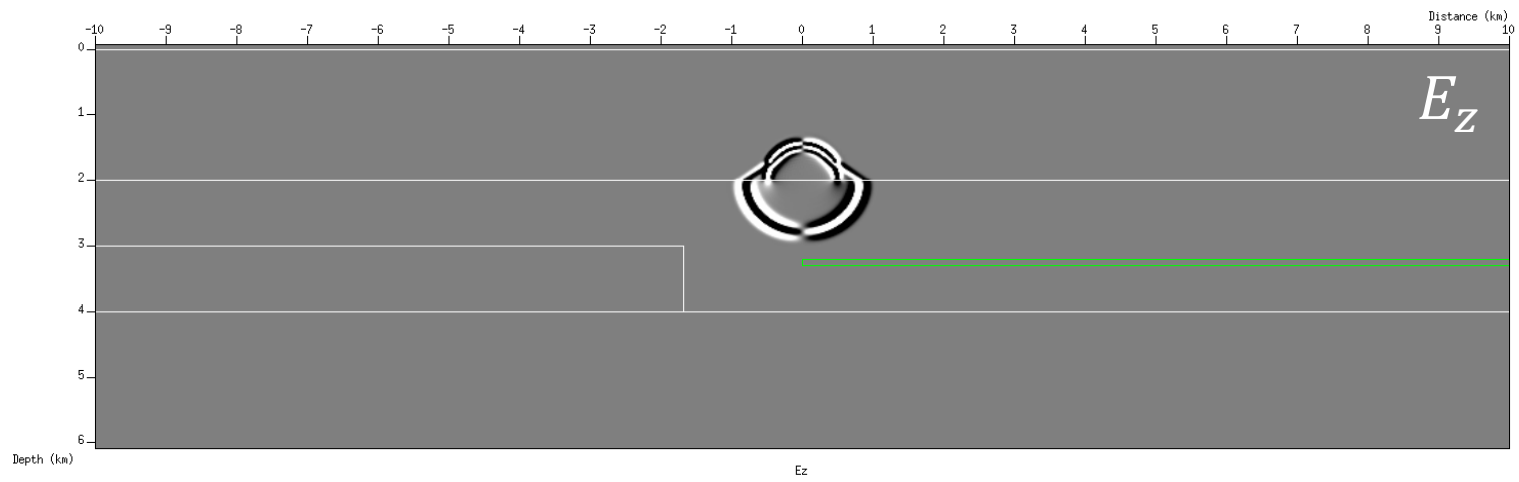
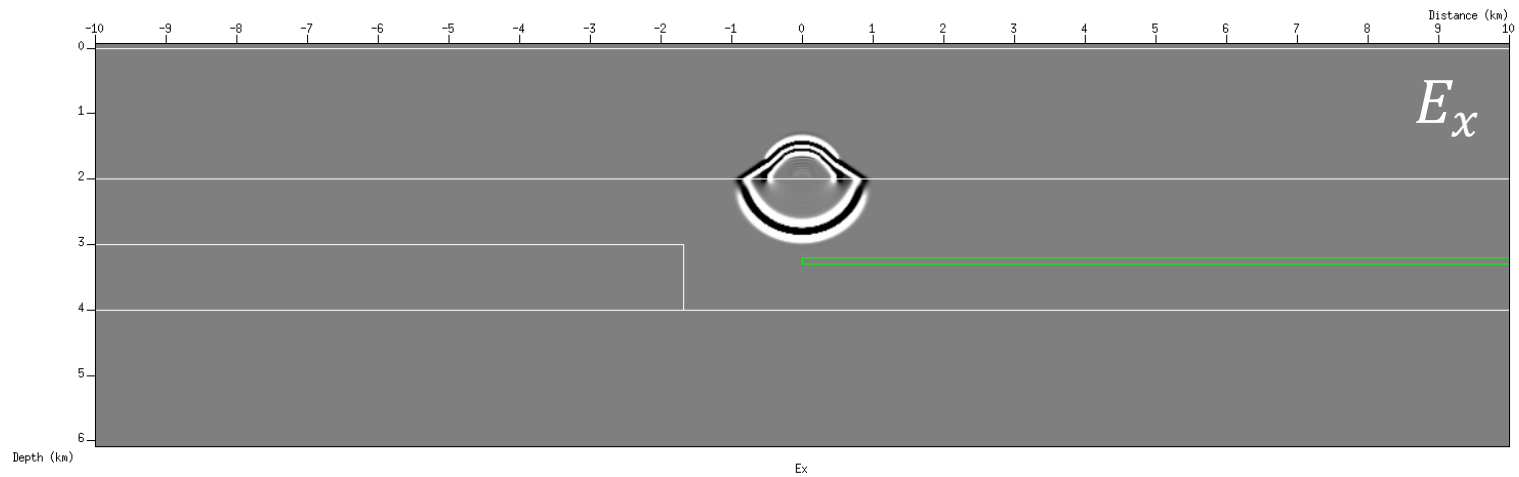

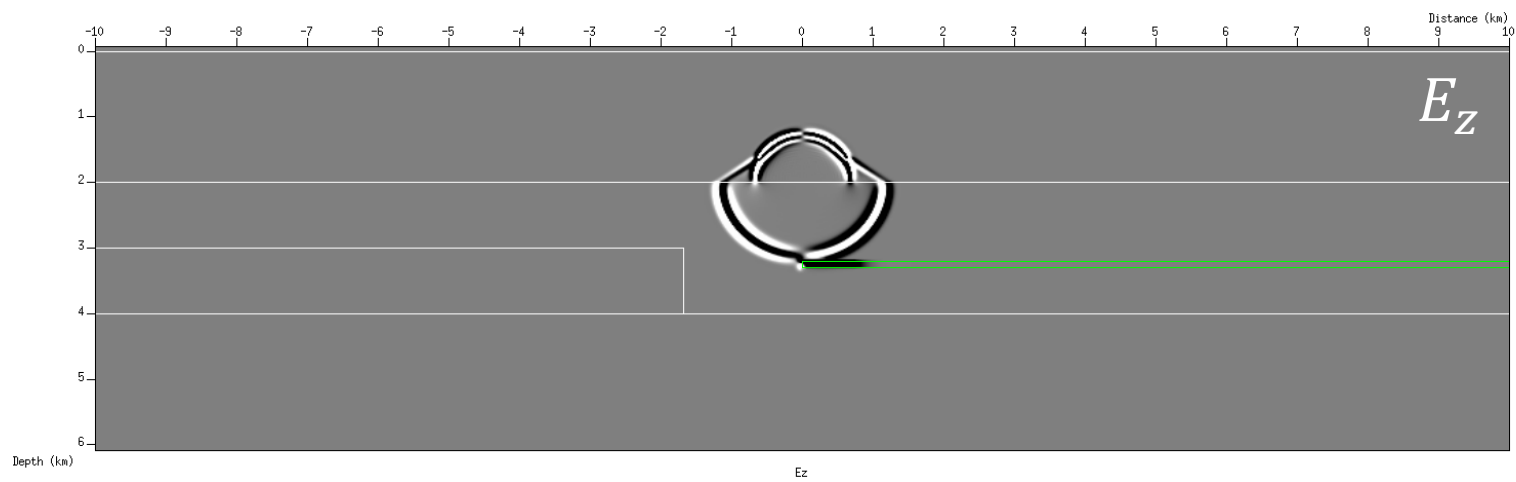
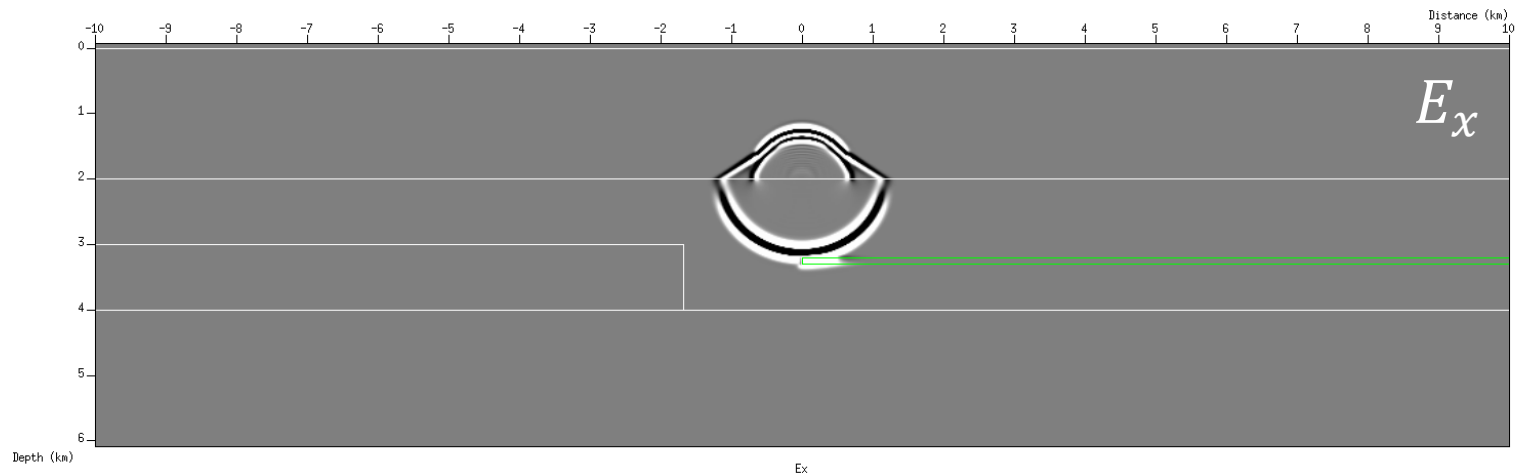

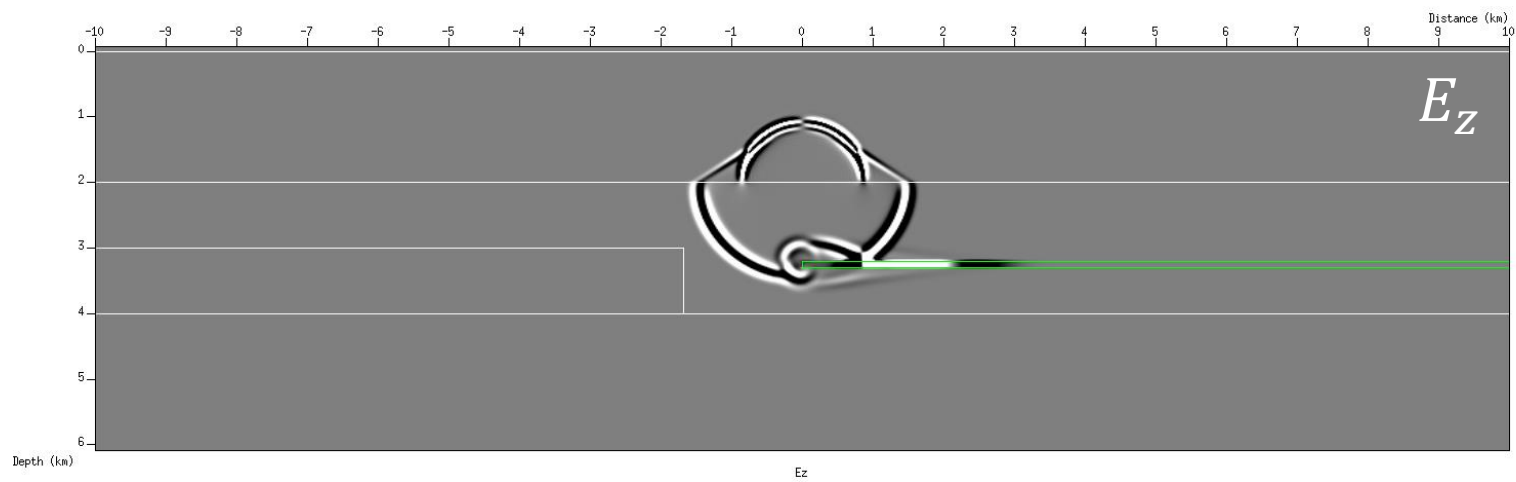
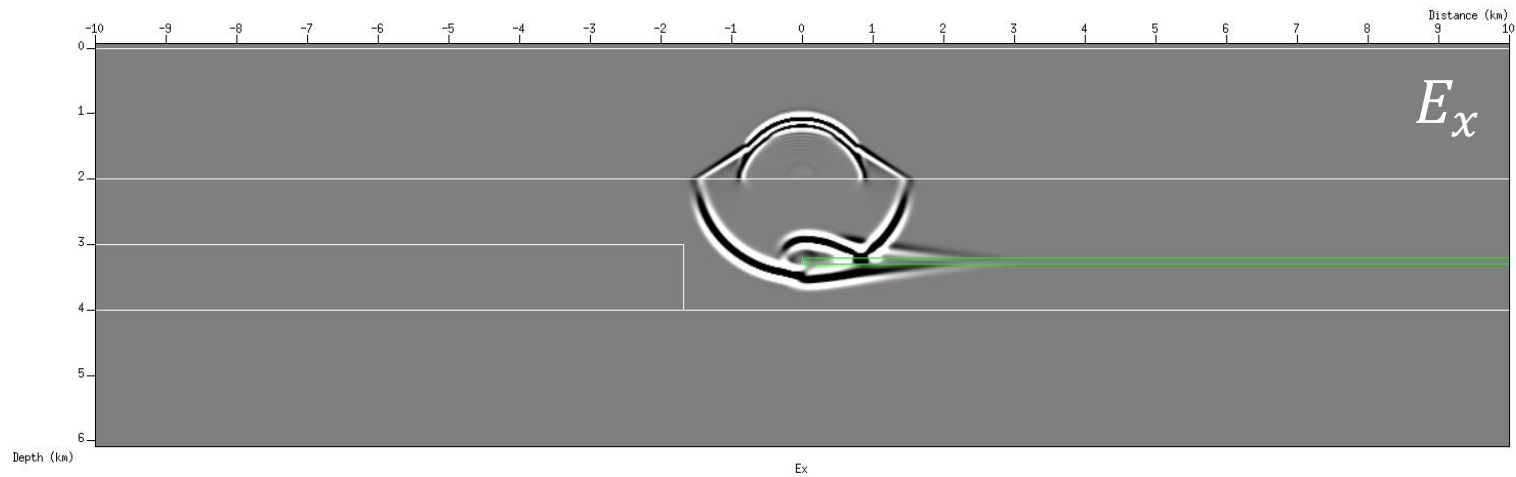

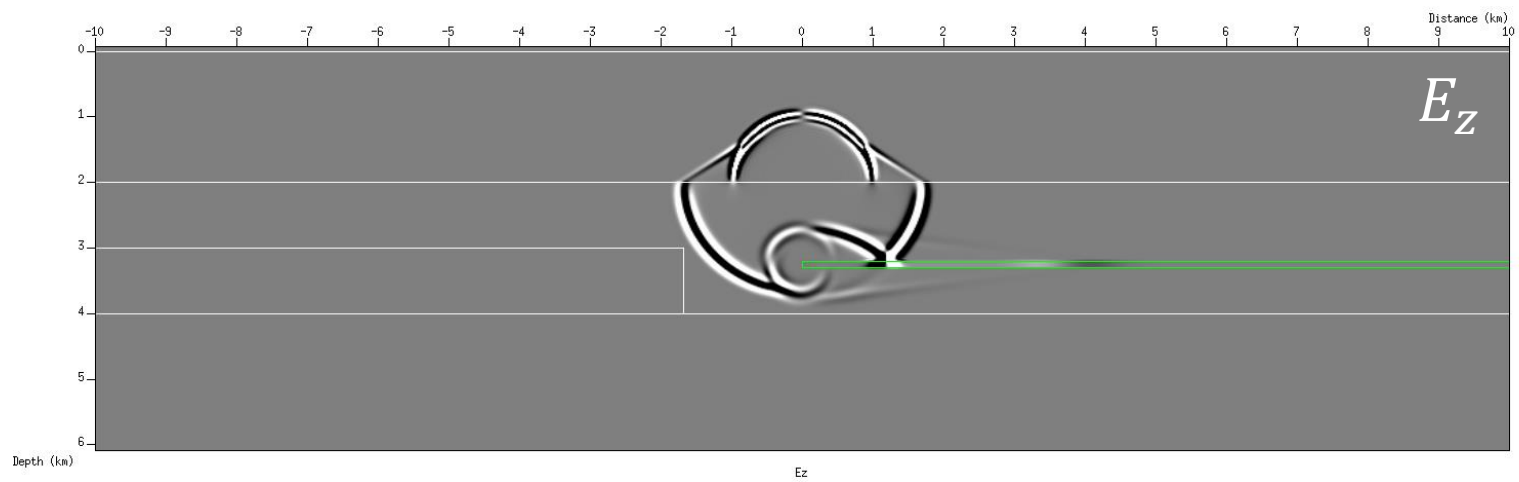
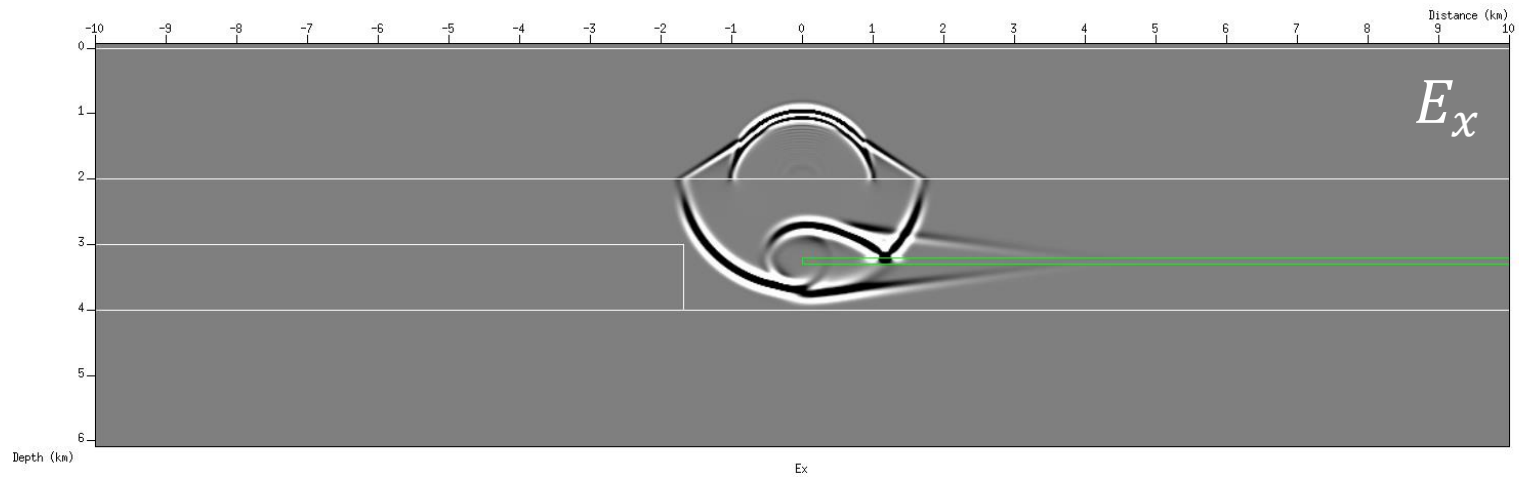

$$E_i(x, \omega) = \int_0^T dt' E'_i(x, t') e^{-\sqrt{\omega\omega_0}t'} e^{i\sqrt{\omega\omega_0}t'}$$

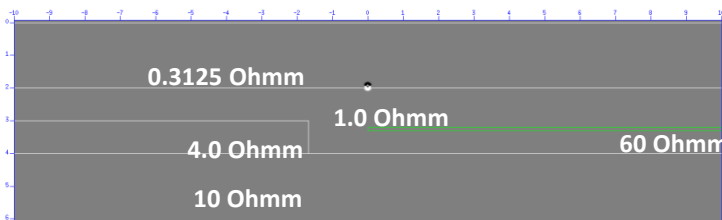
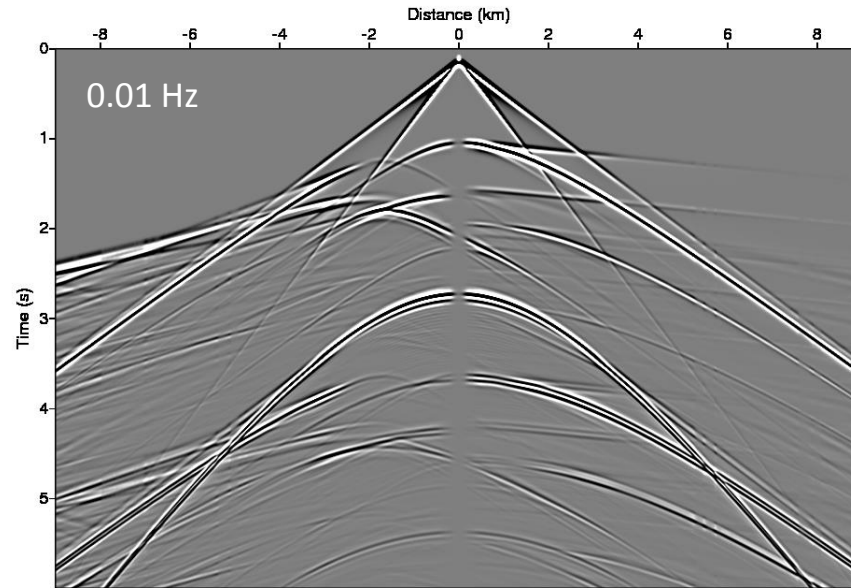
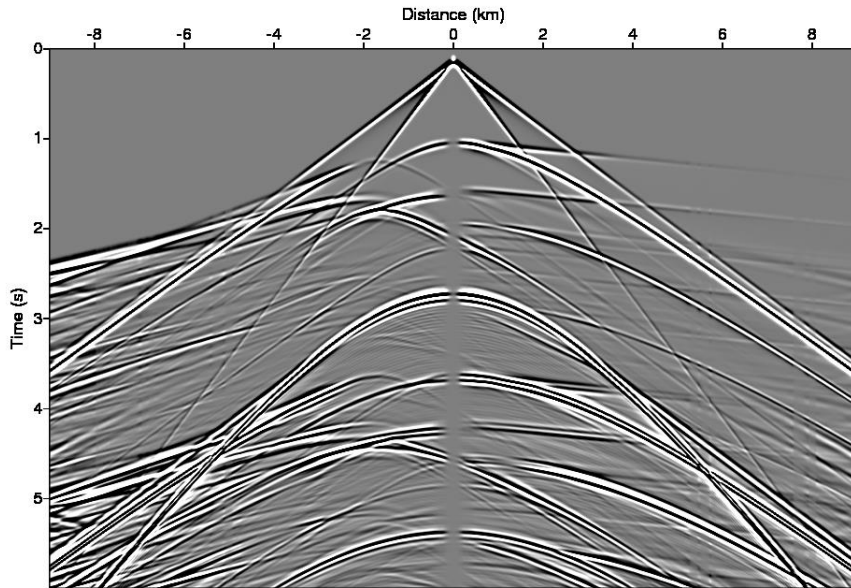

Note: Reflections are important at very low frequencies

$$E_i(\mathbf{x}, \omega) = \int_0^T dt' E'_i(\mathbf{x}, t') e^{-\sqrt{\omega\omega_0}t'} e^{i\sqrt{\omega\omega_0}t'}$$

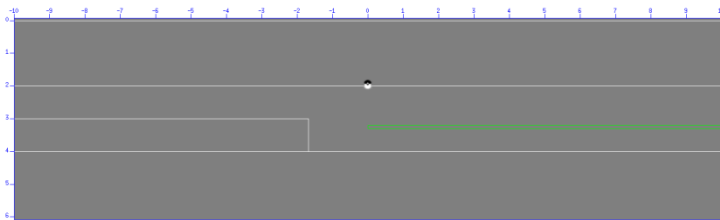
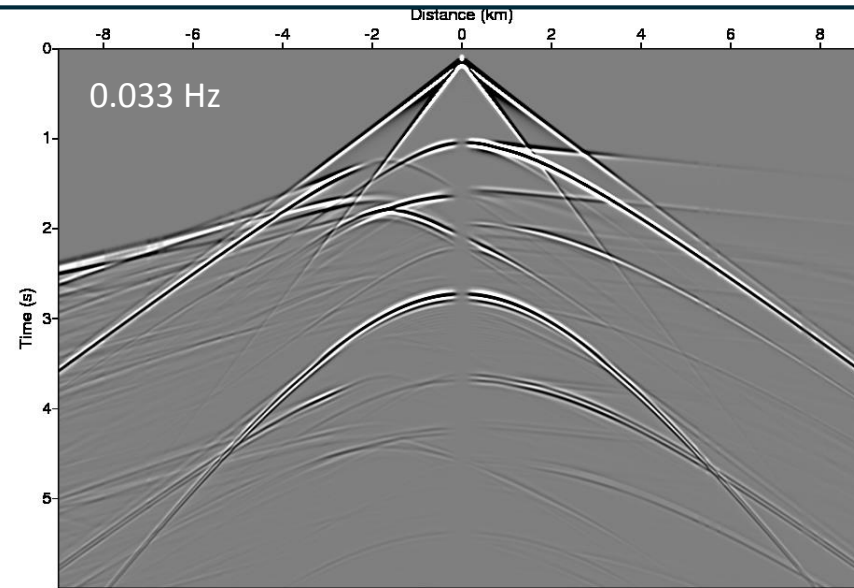
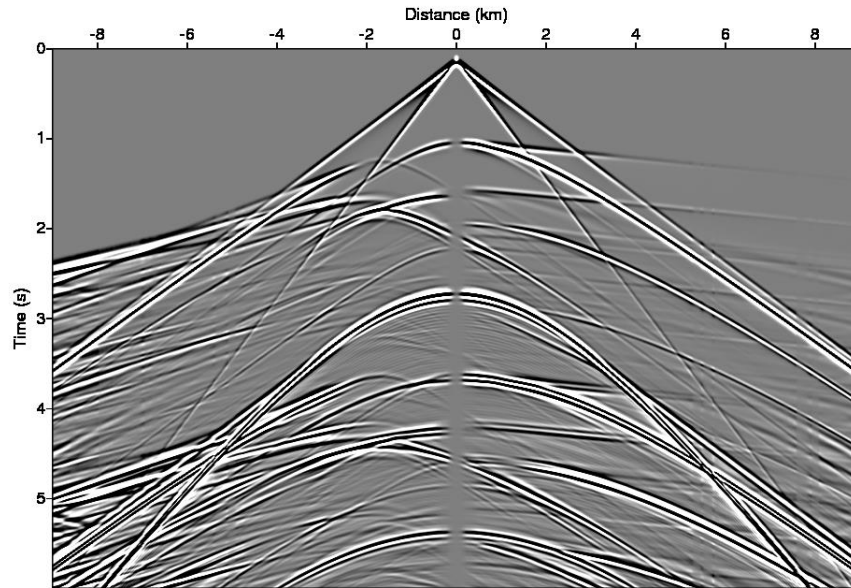

$$E_i(\mathbf{x}, \omega) = \int_0^T dt' E'_i(\mathbf{x}, t') e^{-\sqrt{\omega\omega_0}t'} e^{i\sqrt{\omega\omega_0}t'}$$

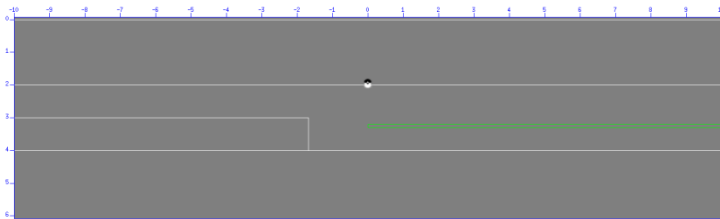
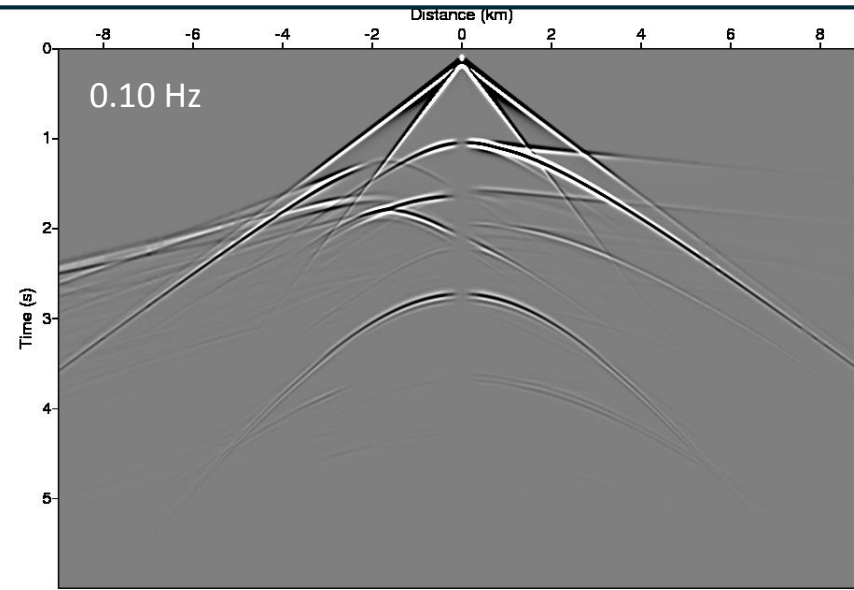
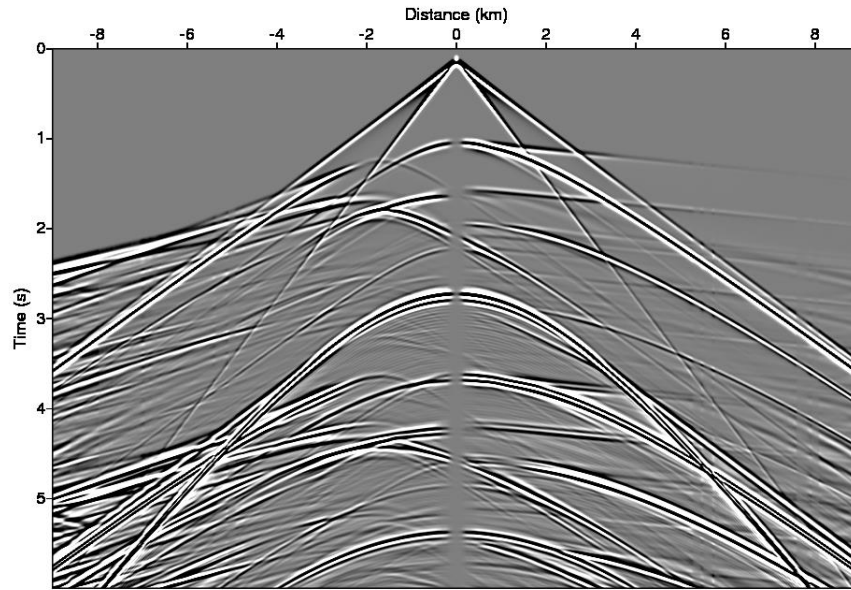

$$E_i(\mathbf{x}, \omega) = \int_0^T dt' E'_i(\mathbf{x}, t') e^{-\sqrt{\omega\omega_0}t'} e^{i\sqrt{\omega\omega_0}t'}$$

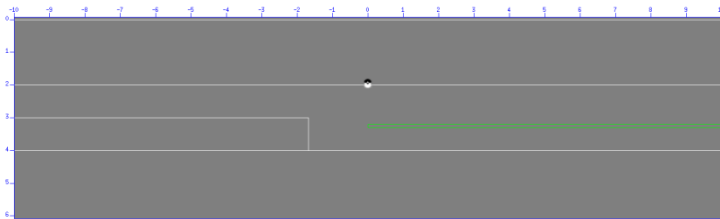
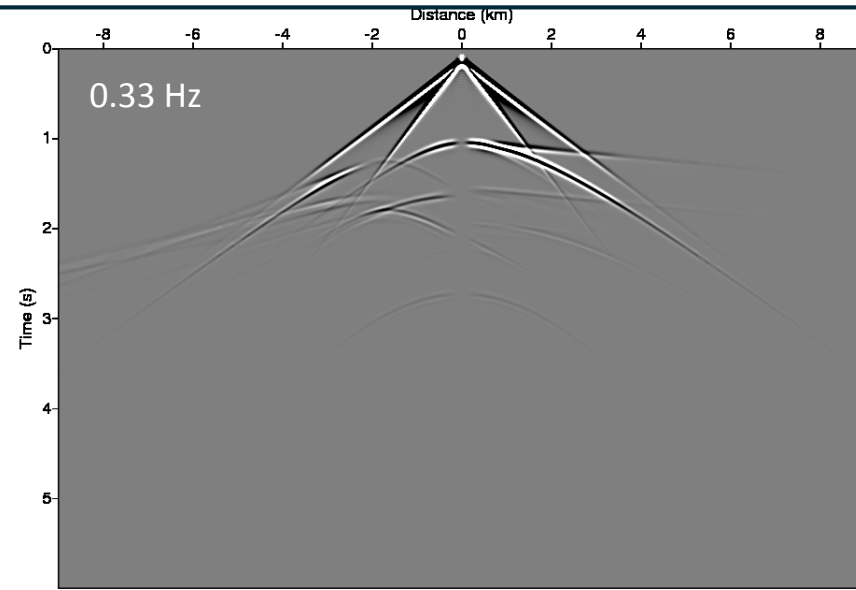
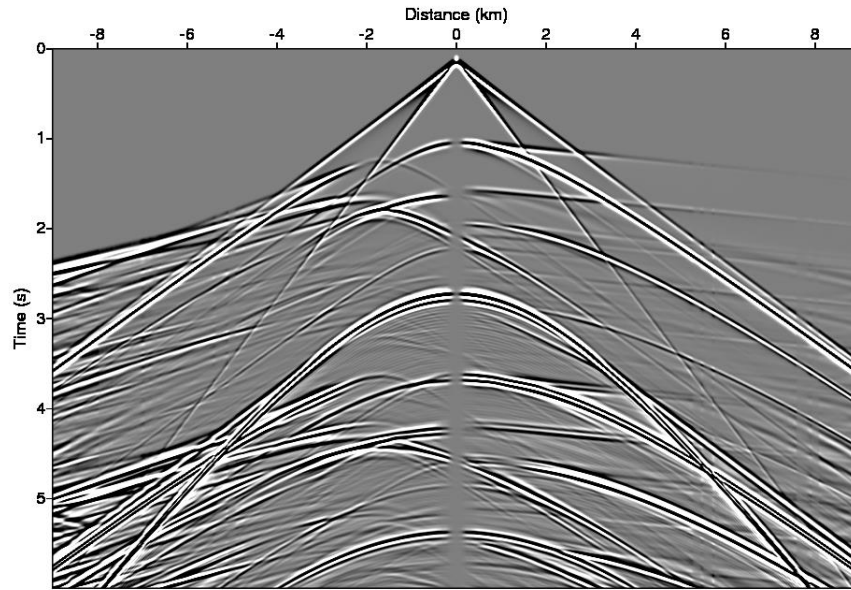

$$E_i(\mathbf{x}, \omega)$$

$$= \int_0^T dt' E'_i(\mathbf{x}, t') e^{-\sqrt{\omega\omega_0}t'} e^{i\sqrt{\omega\omega_0}t'}$$

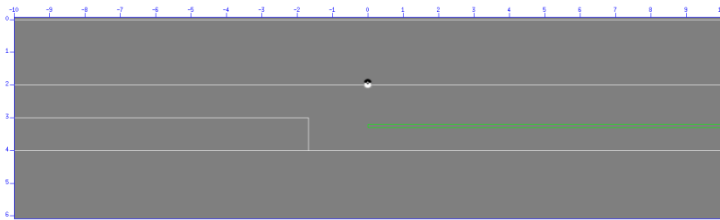
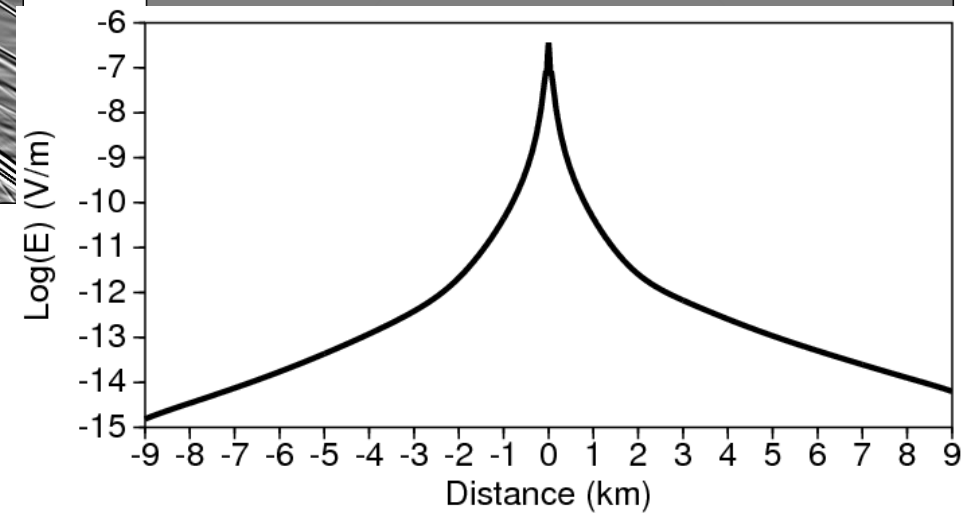
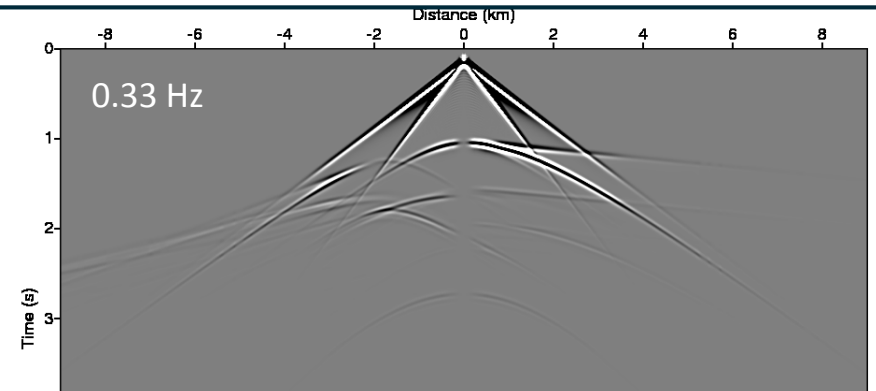
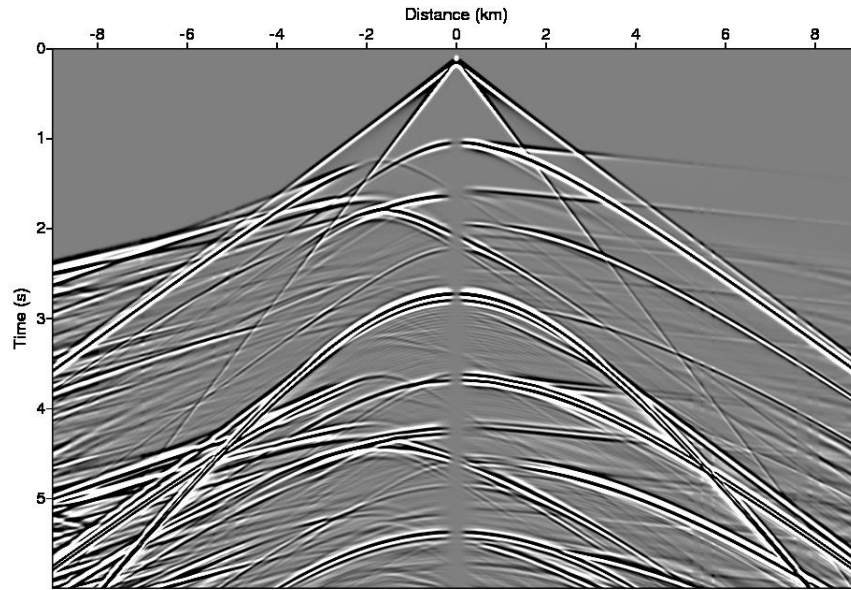

$$E_i(\mathbf{x}, \omega)$$

$$= \int_0^T dt' E'_i(\mathbf{x}, t') e^{-\sqrt{\omega\omega_0}t'} e^{i\sqrt{\omega\omega_0}t'}$$

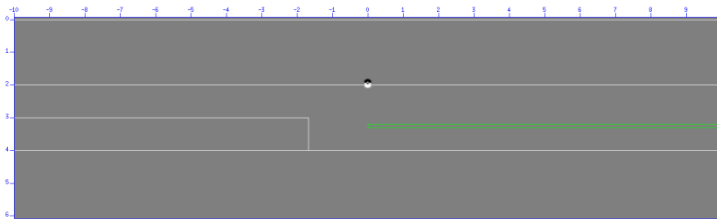
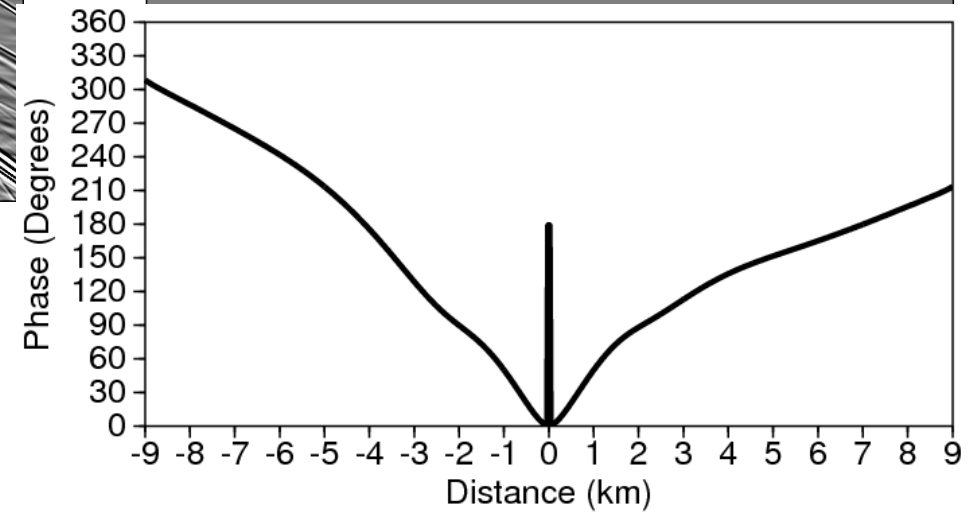
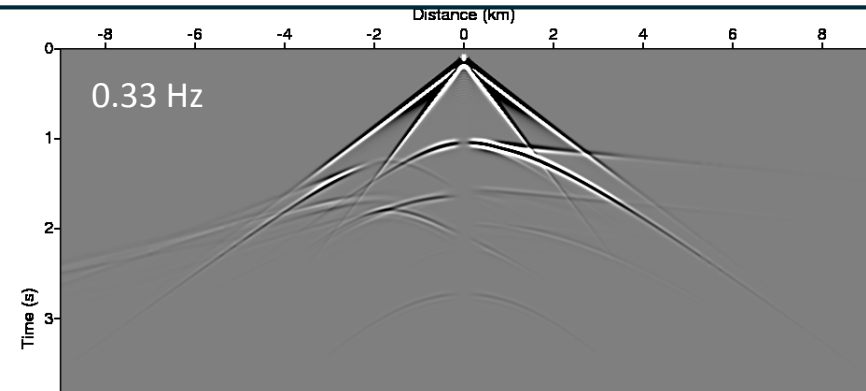
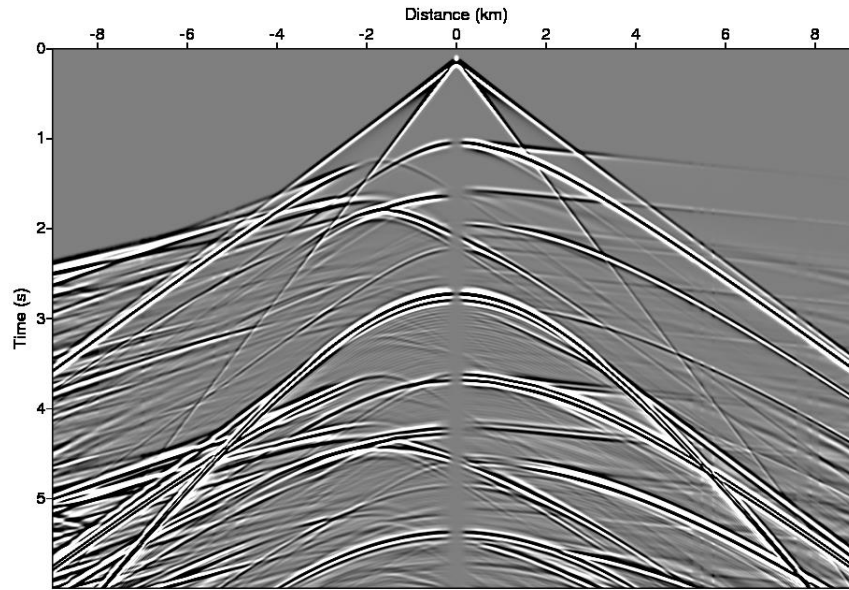

$$E_i(\mathbf{x}, \omega) = \int_0^T dt' E'_i(\mathbf{x}, t') e^{-\sqrt{\omega\omega_0}t'} e^{i\sqrt{\omega\omega_0}t'}$$

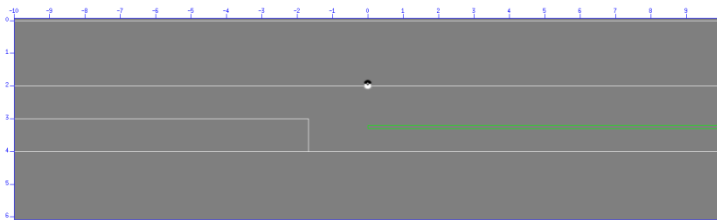
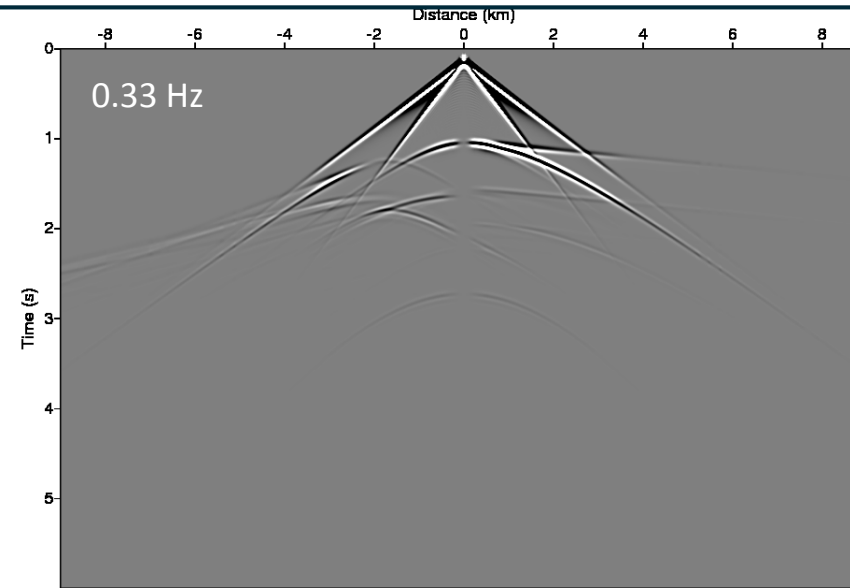
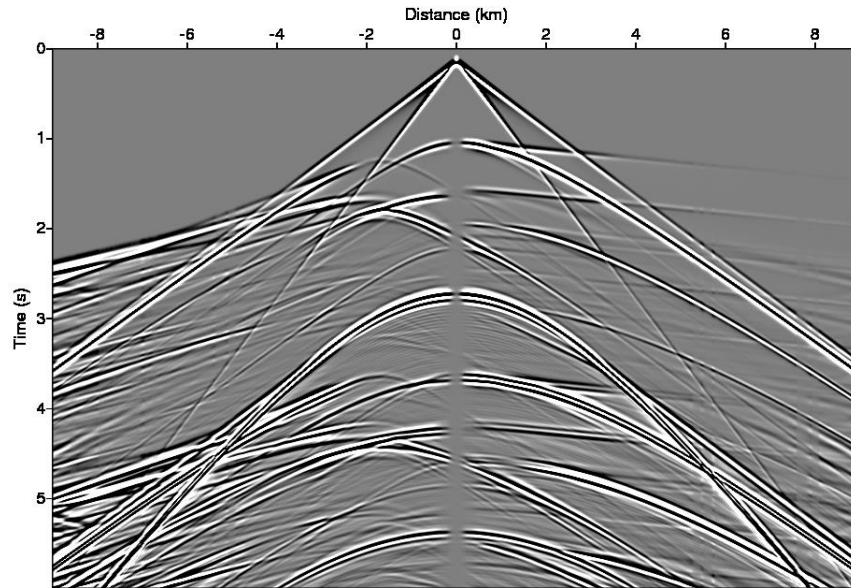

$$E_i(\mathbf{x}, \omega)$$

$$= \int_0^T dt' E'_i(\mathbf{x}, t') e^{-\sqrt{\omega\omega_0}t'} e^{i\sqrt{\omega\omega_0}t'}$$

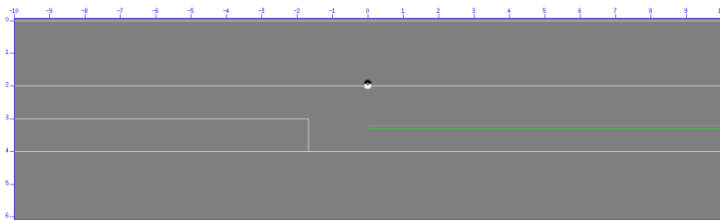
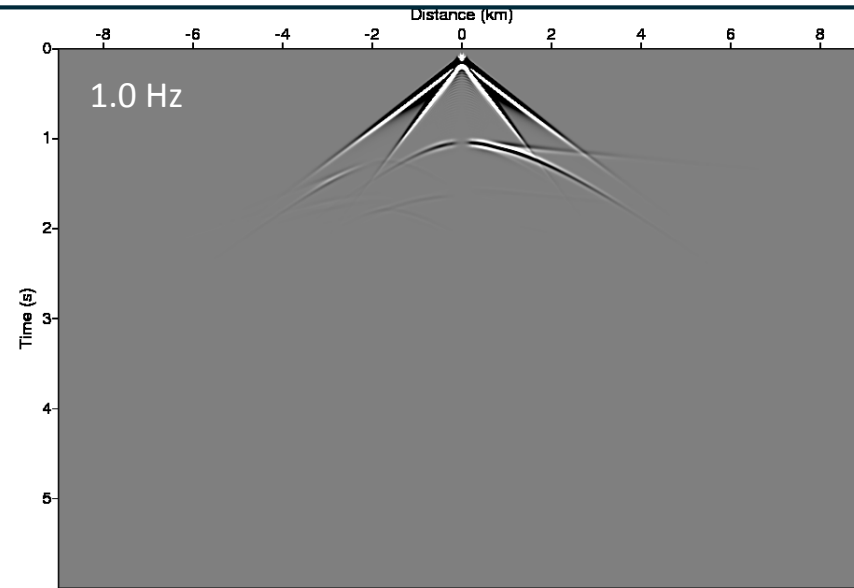
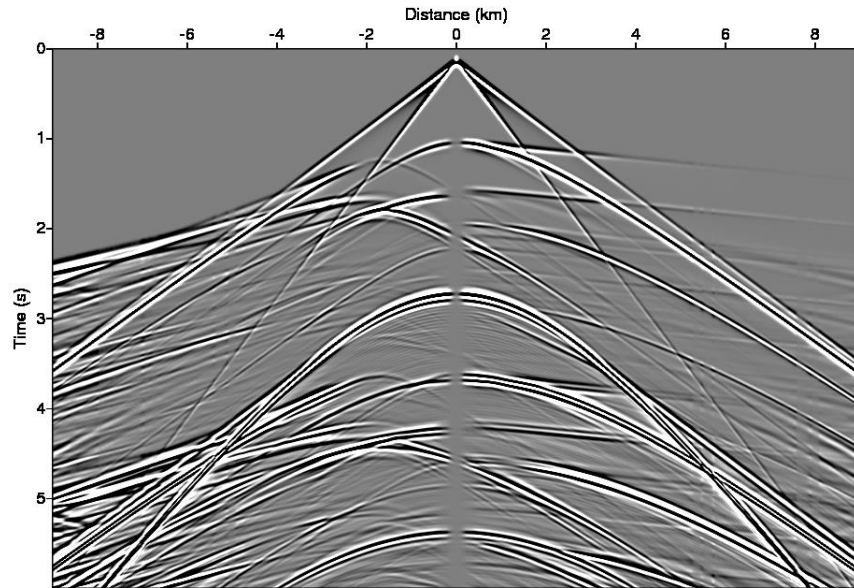

$$E_i(\mathbf{x}, \omega) = \int_0^T dt' E'_i(\mathbf{x}, t') e^{-\sqrt{\omega\omega_0}t'} e^{i\sqrt{\omega\omega_0}t'}$$

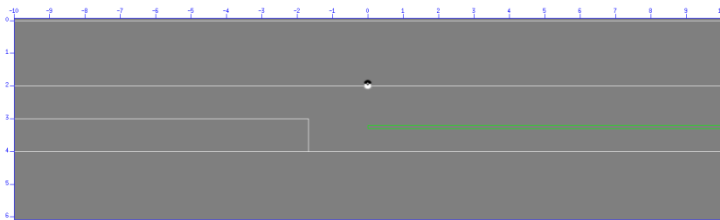
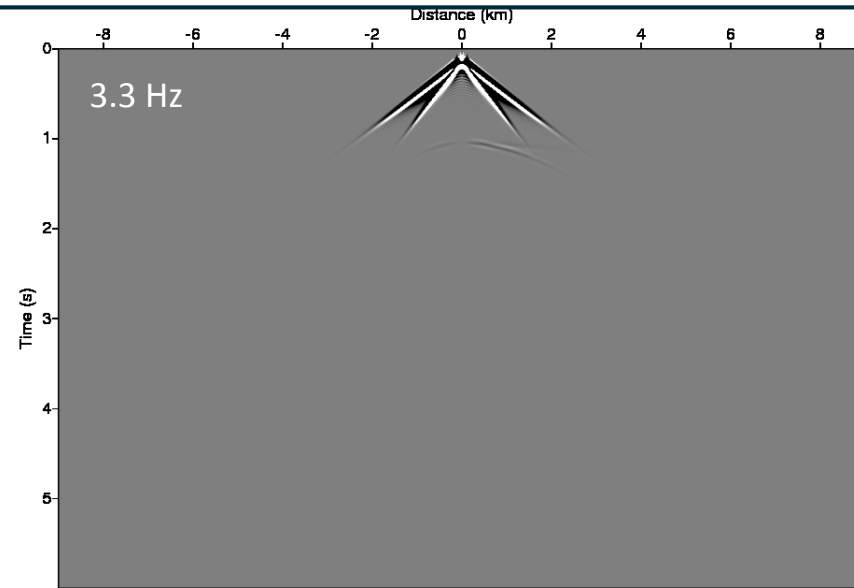
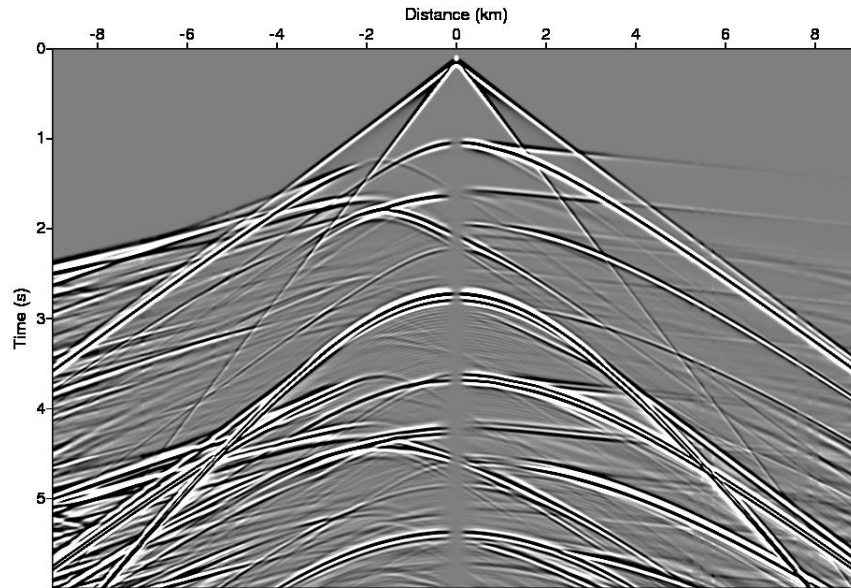

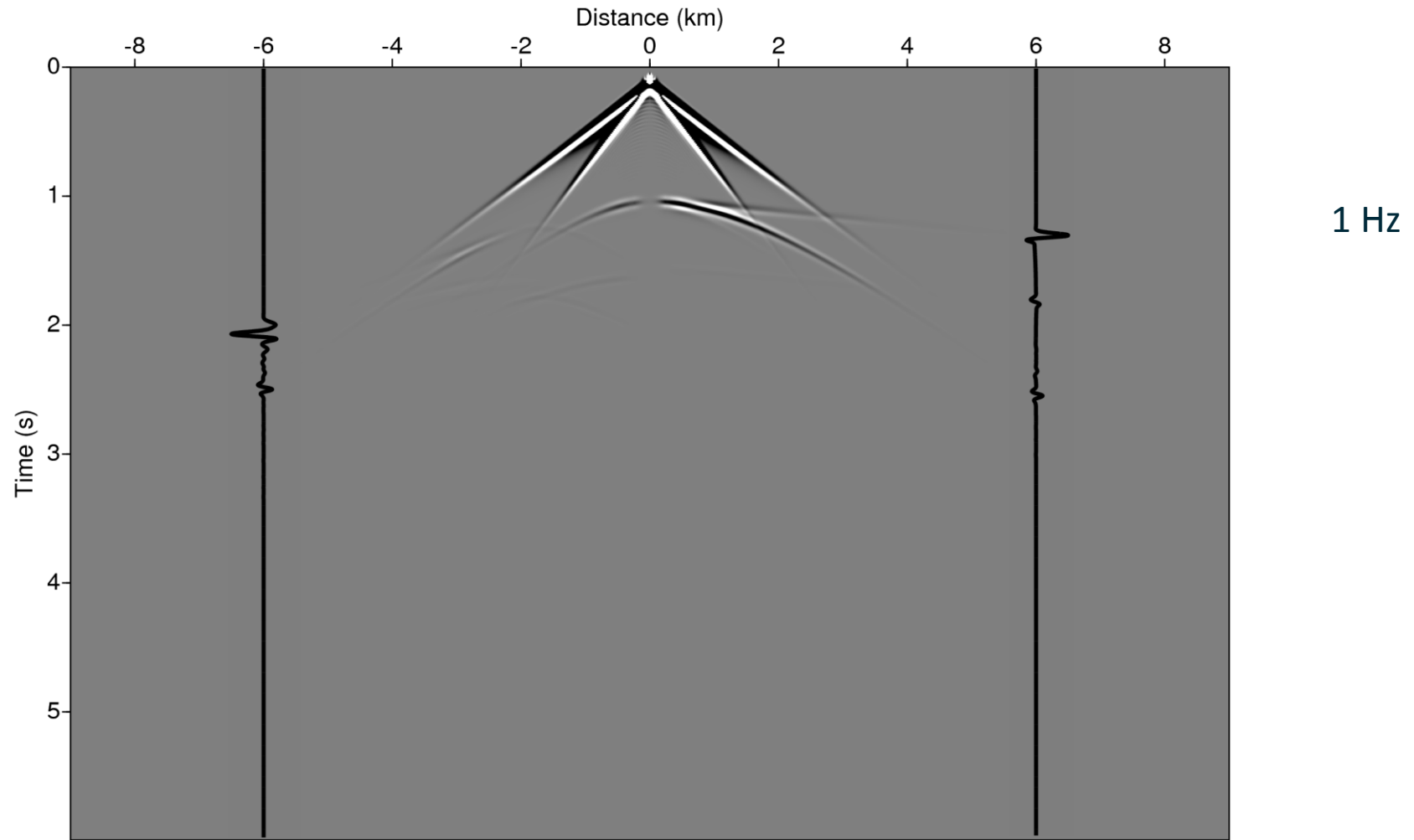

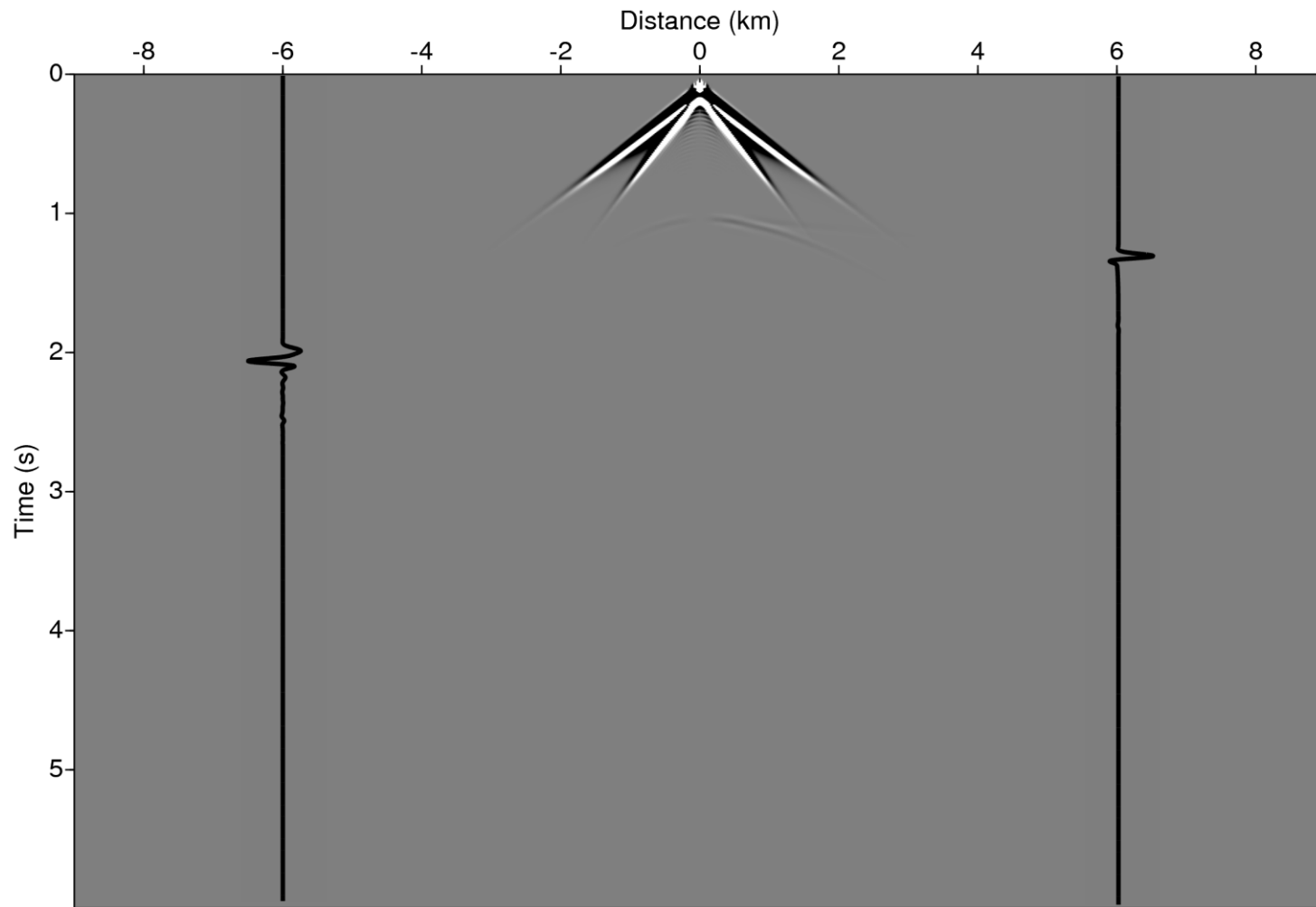

3.3 Hz

Solve the Maxwell equations in the wave domain

$$\nabla^2 \mathbf{E}'(\mathbf{x}, t') - \nabla(\nabla \cdot \mathbf{E}'(\mathbf{x}, t')) - \frac{\mu_0 \sigma(\mathbf{x})}{2\omega_0} \partial_{t'}^2 \mathbf{E}'(\mathbf{x}, t') = \mu_0 \partial_{t'} \mathbf{J}^{Source}(\mathbf{x}, t')$$

Diffusive frequency domain response by transform:

$$\mathbf{E}(\mathbf{x}, \omega) = \int_0^T dt' \mathbf{E}'(\mathbf{x}, t') e^{-\sqrt{\omega\omega_0}t'} e^{i\sqrt{\omega\omega_0}t'}$$

Alternatively, solve directly:

$$\nabla^2 \mathbf{E}(\mathbf{x}, \omega) - \nabla(\nabla \cdot \mathbf{E}(\mathbf{x}, \omega)) + i\omega\mu_0\sigma(\mathbf{x}) \mathbf{E}(\mathbf{x}, \omega) = -i\omega\mu_0 \mathbf{J}^{Source}(\mathbf{x}, \omega)$$

Solution via fictitious time domain and complex frequency back transform
Direct solution of diffusive equation in frequency domain

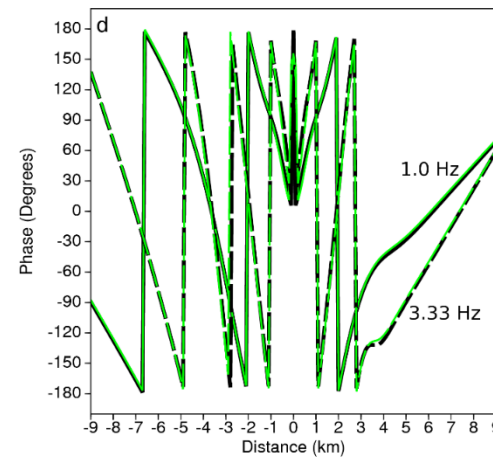
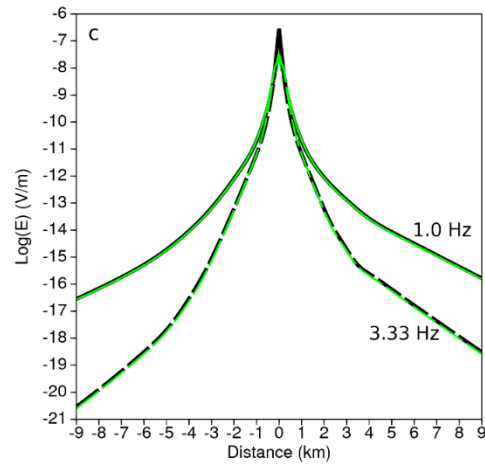
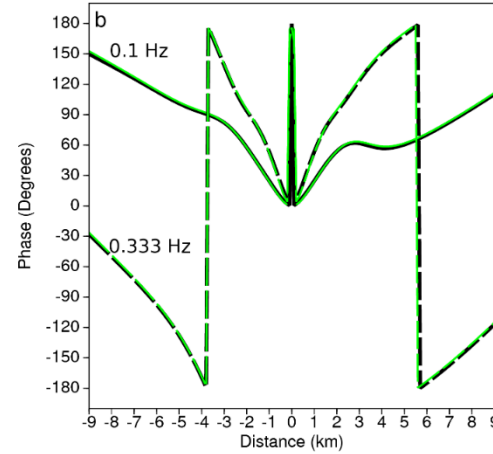
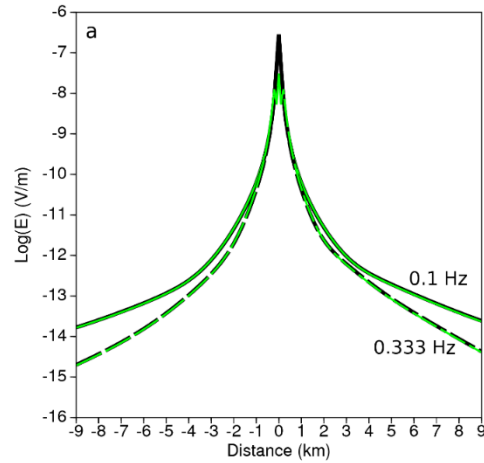

Summary

Transform from fictitious wave-domain time response to «real-world» frequency response by temporal integral

No spatial integration in transform:

What is a reflection or refraction in the EM wave domain
stays a reflection or refraction after the transform to the real frequency domain

No problem using concepts like reflections, refractions, diffractions etc
for interpretation of marine CSEM responses

Note: «use of ray physics» is in principle possible

Summary

For formation resistivities typical for marine sediments and for typical CSEM frequencies:
First arrivals are important - Reflections and refractions at small offsets
- Refractions and guided events at intermediate and large offsets

Guided field in thin resistor gives relatively large electric (and magnetic) fields at large offset. The effect is so strong that it can be used as a hydrocarbon indicator

Marine CSEM responses can be interpreted by inspecting events in the EM wave domain

Marine CSEM data have common properties with refraction seismic data



**SPOT THE
DIFFERENCE.**

Thank you